

製品仕様

SPECIFICATIONS

ツカサ電工株式会社
TSUKASA ELECTRIC CO., LTD.
Rev. K

1. 適用範囲

Scope

- 本仕様書は、ツカサ電工株式会社が貴社に納入する、直流ギヤドモータの製品仕様を規定し適用します。
- This specification provides and applies for the specification of DC Geared Motor supplying you by Tsukasa Electric Co.,Ltd.

2. 仕様書の改訂

Revision

- 本仕様書の記載事項に関する疑義、また、改訂については、双方協議のうえ決定し実施することとします。
- The doubt of article and revision on specification should be discussed and decide to do and it should be accomplished.

3. 仕様書の受領

Receipt

- 受領後の仕様書は、期限を越えて返却が遅れる場合、その間は受領されているものとし処理させていただきます。
- The specification should be recognized to be accepted by you in case that sending specification back was delayed.

4. 機種名

Model No.

TG - 38E - AM - 120 - KA, 24V

5. 定格及び使用条件

Operating condition

項目 ITEM	規格 STANDARD	条件・その他 CONDITIONS・OTHERS
定格電圧 Rated Voltage	24V (D.C.)	安定化電源 Stabilization power supply
定格負荷 Rated Torque	343 [mNm] (3.5 [kgf・cm])	
定格消費電力 Rated Power Consumption	2.9 [W]	
回転方向 Direction Of Rotation	両方向 Both direction	+端子に+印加のときCW (取付面から見て) +voltage applied to + TERMINAL →CW (Seeing from an attachment side)
許容ラジアル荷重 Allowable Radial Road	9.8 [N] (1 [kgf])	軸受面から10[mm]の位置にて The position of 10mm from an axle hole side
許容スラスト荷重 Allowable Thrust Road	6.86 [N] (0.7 [kgf])	
モータ姿勢 Recommended Mounting Position	出力軸水平 Horizontal	
使用温度環境 Operating Temperature	-10~50°C	結露不可 Dew condensation is impossible
使用湿度環境 Operating Humidity	20~90%RH	
保管温度環境 Storage Temperature	-20~60°C	結露不可 Dew condensation is impossible
保管湿度環境 Storage Humidity	10~95%RH	
絶縁耐熱区分 Insulation Class	JIS規格A種<C4003>に基づく Class A(JIS - C4003)	許容最高温度105°C(巻線) Allowable highest temperature:105°C(Winding)
使用電圧範囲 Available Range Of Voltage	24V (D.C.)±10%	
温度上昇 Temperature Rise	モータケース表面にて35deg以下 Max 35deg. On the surface of motor case	定格負荷・定格電圧(温度計法による) Rated Torque・Rated Voltage Consumption
電動機の種類 Electric Motor Type	整流子電動機 Commutator electric motor	
電動機の極数 The Number of Poles of An Electric Motor	2極 2 poles	

6. 機械的特性

Mechanical property

項目 ITEM	規 格 STANDARD	条 件・その他 CONDITIONS・OTHERS
スラストガタ Thrust looseness	0.5 [mm] 以下 Less than 0.5 [mm]	
シャフトの振れ Deflection of a shaft	0.05 [mm] 以下 Less than 0.05 [mm]	取付面から10[mm]の位置にて The position of 10mm from an attachment side
ギヤ許容トルク Gear allowable torque	686 [mNm] (7 [kgf・cm])	

7. 電気的特性

Electrical property

項目 ITEM	規 格 STANDARD	条 件・その他 CONDITIONS・OTHERS
無負荷電流 No Load Current	82 [mA] 以下 (TYP. 22 [mA]) Less than 82 [mA] (TYP. 22 [mA])	定格電圧・無負荷 Rated Voltage・No Load
無負荷回転数 No Load Speed	40.4 [r/min] ± 13%	定格電圧・無負荷 Rated Voltage・No Load
定格電流 Rated Current	180 [mA] 以下 (TYP. 120 [mA]) Less than 180 [mA] (TYP. 120 [mA])	定格電圧・定格負荷 Rated Voltage・Rated Torque
定格回転数 Rated Speed	33.4 [r/min] ± 13%	定格電圧・定格負荷 Rated Voltage・Rated Torque
停動トルク Stall Torque	1372 [mNm] 以上 (14 [kgf・cm]以上) More than 1372 [mNm](More than 14 [kgf・cm])	
停動電流 Stall Current	0.9 [A] 以下 Less than 0.9 [A]	
絶縁抵抗 Insulation Resistance	D.C.500Vにて10[MΩ]以上 10[MΩ]/500V(D.C.)min	入力端子とモータフレーム間 (モータ単体にて、初期値) Between input terminal and motor frame, initial value
絶縁耐圧 Withstand Voltage	A.C.250V(50/60Hz)にて1分間耐えること 1 minute/A.C.250V(50/60Hz)	入力端子とモータフレーム間 (モータ単体にて、初期値) Between input terminal and motor frame, initial value
電気ノイズ対策 The Measure Against An Electric Noise	バリスタ・コイル・セラミックコンデンサ Varistor,Coil,Ceramic condenser	
巻線抵抗 Winding Resistance	30.5 [Ω]	代表値 Nomal
インダクタンス Inductance	36.7 [mH]	代表値 Nomal
トルク定数 Torque Constant	3500 [mNm/A] (35.7 [kgf・cm/A])	代表値 Nomal
誘起電圧定数 Thrust looseness	367.9 [mV/r/min]	代表値 Nomal

※ () は、従来単位を表します。回転数、誘起電圧定数は同じ数値ですので、SI単位のみ記載とさせていただきます。

※ () means conventional unit. Only SI unit would be written as speed and induced voltage constant show same value.

8. 外観及び寸法

Appearance and a size

- ・別紙、外形図参照のこと。
- ・Refer other drawing

- ・傷、汚れ等商品価値を損なう欠陥なきこと。
- ・It should be no scratch or no stain etc. reducing the value on the products.

- ・ネジの締め付け、圧入、カシメ等は緩みなきこと。
- ・Screwing up, press fitting and caulking should have no looseness.

9. 寿命

Expected Life

項目 ITEM	規格 STANDARD	条件・その他 CONDITIONS・OTHERS
寿命 Expected Life	連続500H以上 More than continuation 500 hour	定格電圧・定格負荷 Rated Voltage・Rated Torque 出力軸水平 Horizontal

寿命の定義： 規定寿命経過後、初期値に対して定格回転数が±20%の範囲をこえないこと。
また、機械的騒音の変化については規定しないものとする。

The definition of Life: After a regulation life time has passed, rated speed shall not exceed the range of ±20% against the initial value. Fluctuation of mechanical noise will not be specified.

10. 標準試験状態

Standard test condition

本製品の規格は、温度23℃、相対湿度65%のときを基準とする。
ただし、判定に疑義を生じない場合は温度5～35℃、相対湿度45～85%の環境下で行ってもよい。
This specifications have been measured at ambient temperature 23℃ and 65% relative humidity. Test also will be able to performed at 5-35℃ and 45-85% humidity if results will be same as standard condition.

減速比：1 / 50 ~ 1 / 150

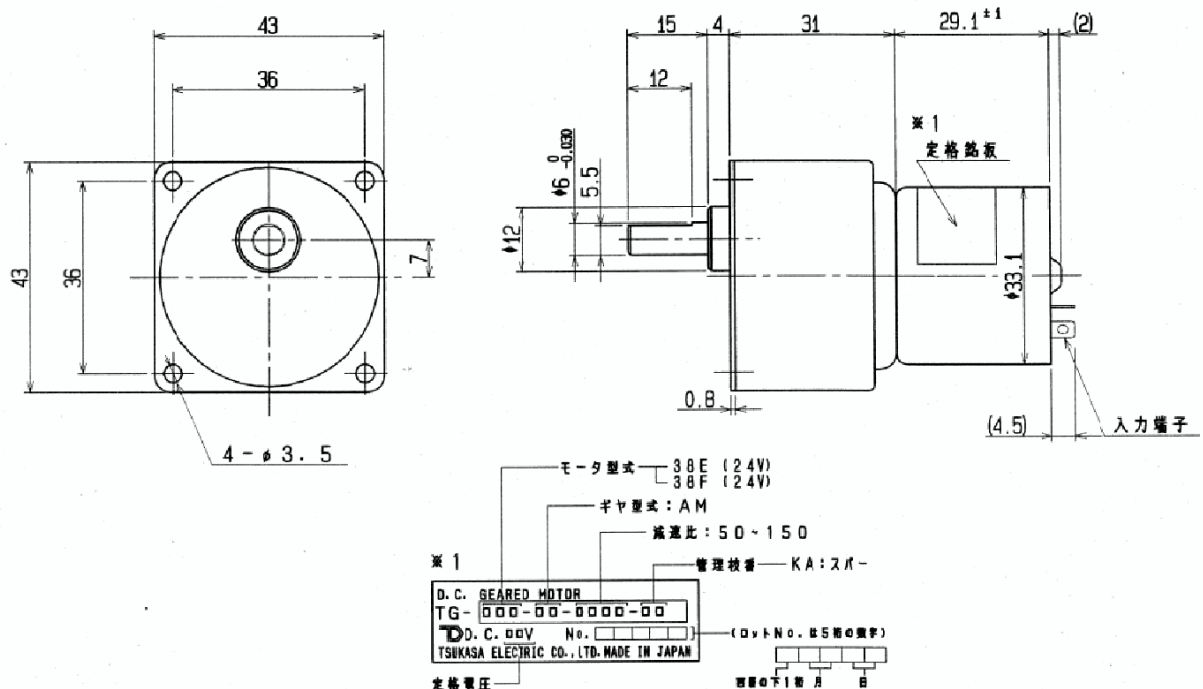

GEARED MOTOR CHARACTERISTICS 2018/01/17

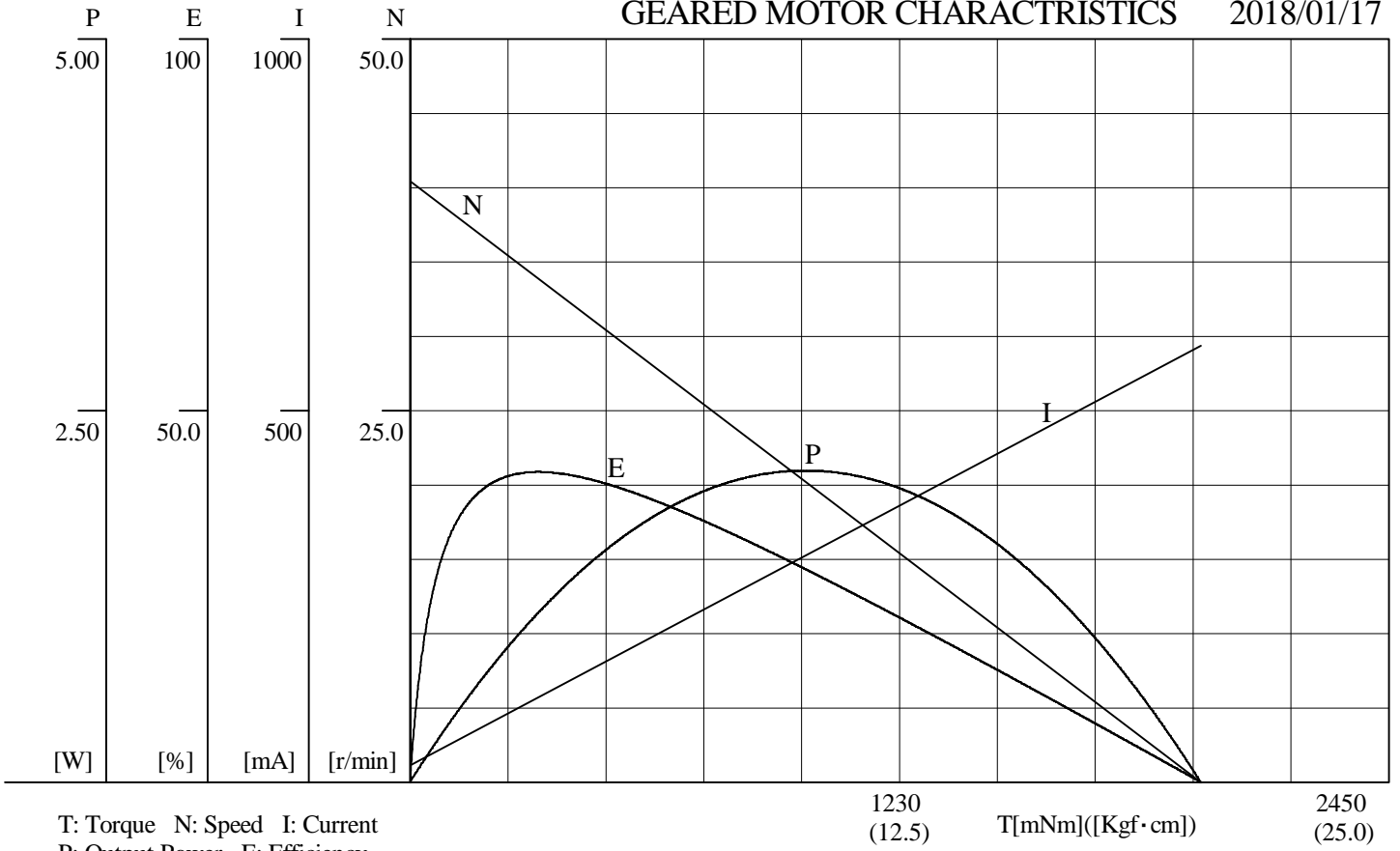

TG-38E-AM-120-KA,24V

24.0 V	T[mNm]	([Kgf·cm])	N[r/min]	I[mA]	P[W]	E[%]
No Load:	0.00	(0.00)	40.4	22.0	0.00	0.0
	49.0	(0.500)	39.4	36.0	0.202	23.4
	98.0	(1.00)	38.4	50.0	0.394	32.9
	147	(1.50)	37.4	64.0	0.576	37.5
	196	(2.00)	36.4	78.0	0.748	39.9
	245	(2.50)	35.4	92.0	0.909	41.2
	294	(3.00)	34.4	106	1.06	41.7
rated	343	(3.50)	33.4	120	1.20	41.7
	392	(4.00)	32.4	134	1.33	41.4
	441	(4.50)	31.4	148	1.45	40.8
	490	(5.00)	30.4	162	1.56	40.1
	539	(5.50)	29.4	176	1.66	39.3
	588	(6.00)	28.4	190	1.75	38.4
	637	(6.50)	27.4	204	1.83	37.4
	686	(7.00)	26.4	218	1.90	36.3
	735	(7.50)	25.4	232	1.96	35.1
Stop Torque:	1980	(20.2)	0.00	588	0.00	0.0
Max Power:	990	(10.1)	20.2	305	2.10	28.6
Max Eff.:	322	(3.28)	33.8	114	1.14	41.7