

# T-1<sup>3</sup>/<sub>4</sub> (5 mm) Precision Optical Performance AllInGaP LED Lamps

## Technical Data

### SunPower Series

HLMP-DLXX	HLMP-GHXX
HLMP-DJXX	HLMP-GGXX
HLMP-DHXX	HLMP-ULXX
HLMP-DGXX	HLMP-UJXX
HLMP-GLXX	<b>HLMP-UHXX</b>
HLMP-GJXX	HLMP-UGXX

### Features

- **Well Defined Spatial Radiation Patterns**
- **Viewing Angles:** 6°, 15°, 23°, 30°
- **High Luminous Output**
- **Colors:**
  - 590 nm Amber
  - 605 nm Orange
  - 615 nm Reddish-Orange
  - 626 nm Red
- **High Operating Temperature:**  
 $T_{j,LED} = +130^{\circ}\text{C}$
- **Superior Resistance to Moisture**
- **Four Package Options:**  
With or Without Flange Base;  
With or Without Lead Stand-Offs

### Benefits

- **Viewing Angles Match Traffic Management Sign Requirements**
- **Colors Meet Automotive and Pedestrian Signal Specifications**
- **Superior Performance in Outdoor Environments**
- **Suitable for Autoinsertion onto PC Boards**

### Applications

- **Traffic Management:**  
Traffic Signals  
Pedestrian Signals  
Work Zone Warning Lights  
Variable Message Signs
- **Commercial Outdoor Advertising:**  
Signs  
Marquees
- **Automotive:**  
Exterior and Interior Lights

### Description

These Precision Optical Performance AllInGaP LEDs provide superior light output for excellent readability in sunlight and are extremely reliable. AllInGaP LED technology provides extremely stable light output over long periods of time. Precision Optical Performance lamps utilize the aluminum indium gallium phosphide (AllInGaP) technology.

These LED lamps are untinted, nondiffused, T-1<sup>3</sup>/<sub>4</sub> packages incorporating second generation optics producing well defined spatial radiation patterns at specific viewing cone angles.

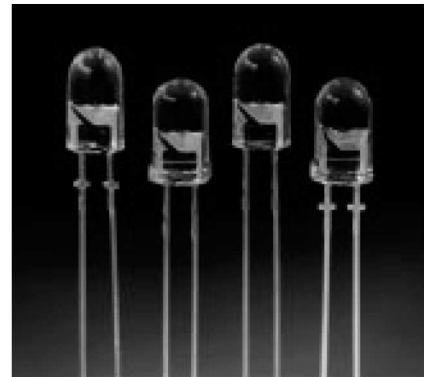

These lamps are made with an advanced optical grade epoxy, offering superior high temperature and high moisture resistance performance in outdoor signal and sign applications. The high maximum LED junction temperature limit of +130°C enables high temperature operation in bright sunlight conditions. The package epoxy contains both uv-a and uv-b inhibitors to reduce the effects of long term exposure to direct sunlight.

These lamps are available in four package options to give the designer flexibility with device mounting.

## Device Selection Guide

Part Number HLMP-	Typical Viewing Angle, $2\theta_{1/2}$ (Deg.) <sup>[4]</sup>	Color, Dominant Wavelength, $\lambda_d$ (nm), <sup>[3]</sup> Typ.	Luminous Intensity, $I_v$ (mcd), <sup>[1,2]</sup> @ 20 mA		Leads with Stand-Offs	Flanged Base	Package Drawing
			Min.	Typ.			
DL08 <sup>[5]</sup>	6	Amber, 590	4000	9300	No	Yes	A
GL08 <sup>[5]</sup>	6	Amber, 590	4000	9300	No	No	B
DL10 <sup>[5]</sup>	6	Amber, 590	4000	9300	Yes	Yes	C
GL10 <sup>[5]</sup>	6	Amber, 590	4000	9300	Yes	No	D
UL06 <sup>[5]</sup>	6	Amber, 590	1600	4000	No	Yes	A
UL07 <sup>[5]</sup>	6	Amber, 590	1600	4000	Yes	Yes	C
DJ08 <sup>[5]</sup>	6	Orange, 605	4200	9500	No	Yes	A
GJ08 <sup>[5]</sup>	6	Orange, 605	4200	9500	No	No	B
DJ10 <sup>[5]</sup>	6	Orange, 605	4200	9500	Yes	Yes	C
GJ10 <sup>[5]</sup>	6	Orange, 605	4200	9500	Yes	No	D
UJ06 <sup>[5]</sup>	6	Orange, 605	2000	4500	No	Yes	A
UJ07 <sup>[5]</sup>	6	Orange, 605	2000	4500	Yes	Yes	C
DH08 <sup>[5]</sup>	6	Red-Orange, 615	2900	8000	No	Yes	A
GH08 <sup>[5]</sup>	6	Red-Orange, 615	2900	8000	No	No	B
DH10 <sup>[5]</sup>	6	Red-Orange, 615	2900	8000	Yes	Yes	C
GH10 <sup>[5]</sup>	6	Red-Orange, 615	2900	8000	Yes	No	D
UH06 <sup>[5]</sup>	6	Rcd-Orange, 615	1400	3500	No	Yes	A
UH07 <sup>[5]</sup>	6	Red-Orange, 615	1400	3500	Yes	Yes	C
DG08 <sup>[5]</sup>	6	Red, 626	2900	6500	No	Yes	A
GG08 <sup>[5]</sup>	6	Red, 626	2900	6500	No	No	B
DG10 <sup>[5]</sup>	6	Red, 626	2900	6500	Yes	Yes	C
GG10 <sup>[5]</sup>	6	Red, 626	2900	6500	Yes	No	D
UG06 <sup>[5]</sup>	6	Red, 626	1000	3000	No	Yes	A
UG07 <sup>[5]</sup>	6	Rcd, 626	1000	3000	Yes	Yes	C
DL15	15	Amber, 590	1600	3100	No	Yes	A
GL15	15	Amber, 590	1600	3100	No	No	B
DL17	15	Amber, 590	1600	3100	Yes	Yes	C
GL17	15	Amber, 590	1600	3100	Yes	No	D
UL13	15	Amber, 590	700	1600	No	Yes	A
UL14	15	Amber, 590	700	1600	Yes	Yes	C
DJ15	15	Orange, 605	1400	3400	No	Yes	A
GJ15	15	Orange, 605	1400	3400	No	No	B
DJ17	15	Orange, 605	1400	3400	Yes	Yes	C
GJ17	15	Orange, 605	1400	3400	Yes	No	D

### Notes:

1. The luminous intensity is measured on the mechanical axis of the lamp package.
2. The optical axis is closely aligned with the package mechanical axis.
3. The dominant wavelength,  $\lambda_d$ , is derived from the CIE Chromaticity Diagram and represents the color of the lamp.
4.  $\theta_{1/2}$  is the off-axis angle where the luminous intensity is one half the on-axis intensity.
5. The intensity of narrow viewing angle lamps is measured at the intensity peak.

# Package Dimensions

**A**

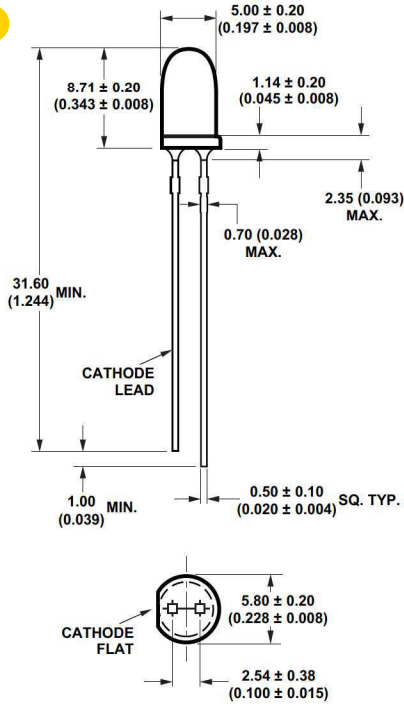

**C**

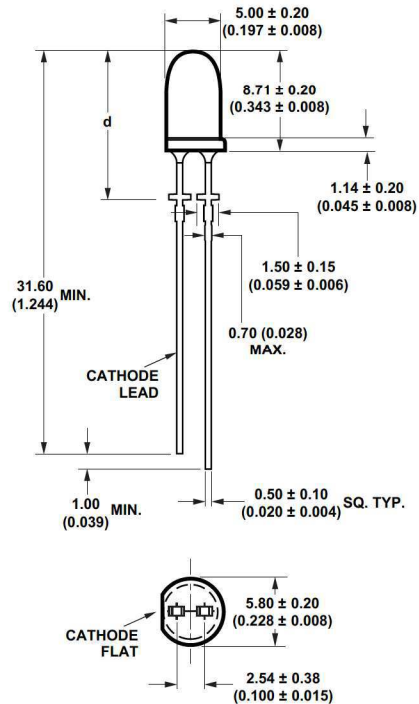

**B**

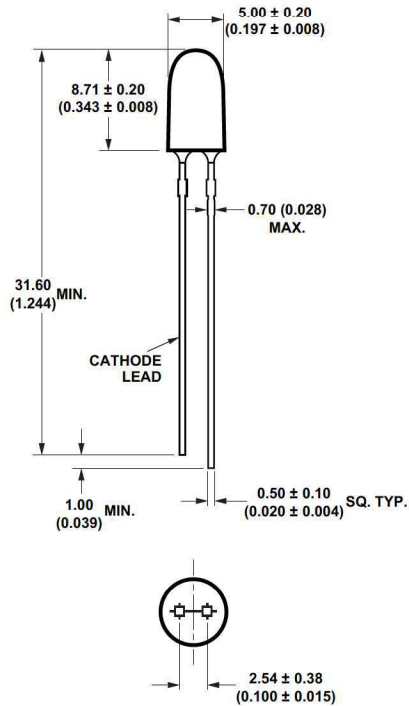

**D**

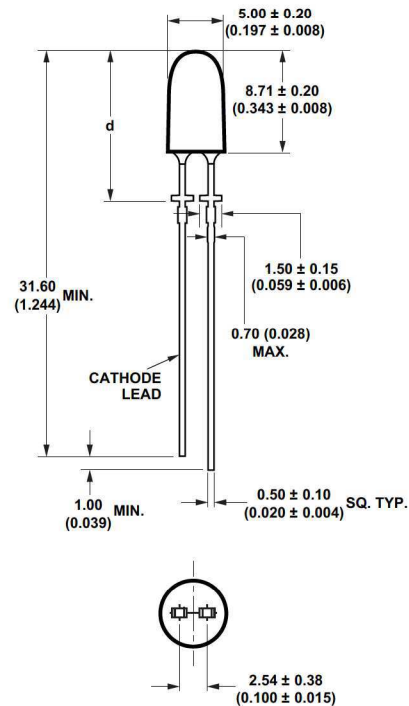

**NOTES:**

1. ALL DIMENSIONS ARE IN MILLIMETERS (INCHES).
2. LEADS ARE MILD STEEL, SOLDER DIPPED.
3. TAPERS SHOWN AT TOP OF LEADS (BOTTOM OF LAMP PACKAGE) INDICATE AN EPOXY MENISCUS THAT MAY EXTEND ABOUT 1 mm (0.040 in.) DOWN THE LEADS.
4. RECOMMENDED PC BOARD HOLE DIAMETERS:
  - LAMP PACKAGES A AND B WITHOUT STAND-OFFS: FLUSH MOUNTING AT BASE OF LAMP PACKAGE = 1.143/1.067 (0.044/0.042).
  - LAMP PACKAGES C AND D WITH STAND-OFFS: MOUNTING AT LEAD STAND-OFFS = 0.965/0.889 (0.038/0.035).
5. FOR DOME HEIGHTS ABOVE LEAD STAND-OFF SEATING PLANE,  $d$ , LAMP PACKAGES C AND D, SEE TABLE.

PART NO.	$d$
HLMP-XX10	$12.37 \pm 0.25$
-XX07	$(0.487 \pm 0.010)$
HLMP-XX17	$12.42 \pm 0.25$
-XX14	$(0.489 \pm 0.010)$
HLMP-XX26	$12.52 \pm 0.25$
-XX23	$(0.493 \pm 0.010)$
HLMA-XX32	$11.96 \pm 0.25$
-XX29	$(0.471 \pm 0.010)$

### Absolute Maximum Ratings at $T_A = 25^\circ\text{C}$

DC Forward Current <sup>[1,2,3]</sup> .....	50 mA
Peak Pulsed Forward Current <sup>[2,3]</sup> .....	70 mA
Average Forward Current <sup>[3]</sup> .....	30 mA
Reverse Voltage ( $I_R = 100 \mu\text{A}$ ) .....	5 V
LED Junction Temperature .....	130°C
Operating Temperature .....	-40°C to +100°C
Storage Temperature .....	-40°C to +120°C
Soldering Temperature .....	260°C for 5 seconds
[1.59 mm (0.060 in.) below seating plane]	

#### Notes:

1. Derate linearly as shown in Figure 4.
2. For long term performance with minimal light output degradation, drive currents between 10 mA and 30 mA are recommended.
3. Please contact your Hewlett-Packard sales representative about operating currents below 10 mA.

### Electrical/Optical Characteristics at $T_A = 25^\circ\text{C}$

Parameter	Symbol	Min.	Typ.	Max.	Units	Test Conditions
Forward Voltage Amber ( $\lambda_d = 590 \text{ nm}$ ) Orange ( $\lambda_d = 605 \text{ nm}$ ) Red-Orange ( $\lambda_d = 615 \text{ nm}$ ) Red ( $\lambda_d = 626 \text{ nm}$ )	$V_F$		2.02 1.98 1.94 1.90	2.4	V	$I_F = 20 \text{ mA}$
Reverse Voltage	$V_R$	5	20		V	$I_F = 100 \mu\text{A}$
Peak Wavelength: Amber ( $\lambda_d = 590 \text{ nm}$ ) Orange ( $\lambda_d = 605 \text{ nm}$ ) Red-Orange ( $\lambda_d = 615 \text{ nm}$ ) Red ( $\lambda_d = 626 \text{ nm}$ )	$\lambda_{\text{PEAK}}$		592 609 621 635		nm	Peak of Wavelength of Spectral Distribution at $I_F = 20 \text{ mA}$
Spectral Halfwidth	$\Delta\lambda_{1/2}$		17		nm	Wavelength Width at Spectral Distribution $1/2$ Power Point at $I_F = 20 \text{ mA}$
Speed of Response	$\tau_s$		20		ns	Exponential Time Constant, $e^{-t/\tau_s}$
Capacitance	C		40		pF	$V_F = 0, f = 1 \text{ MHz}$
Thermal Resistance	$R\theta_{\text{J-PIN}}$		240		$^\circ\text{C/W}$	LED Junction-to-Cathode Lead
Luminous Efficacy <sup>[1]</sup> Amber ( $\lambda_d = 590 \text{ nm}$ ) Orange ( $\lambda_d = 605 \text{ nm}$ ) Red-Orange ( $\lambda_d = 615 \text{ nm}$ ) Red ( $\lambda_d = 626 \text{ nm}$ )	$\eta_v$		480 370 260 150		lm/W	Emitted Luminous Power/Emitted Radiant Power

#### Note:

1. The radiant intensity,  $I_e$ , in watts per steradian, may be found from the equation  $I_e = I_v/\eta_v$ , where  $I_v$  is the luminous intensity in candelas and  $\eta_v$  is the luminous efficacy in lumens/watt.

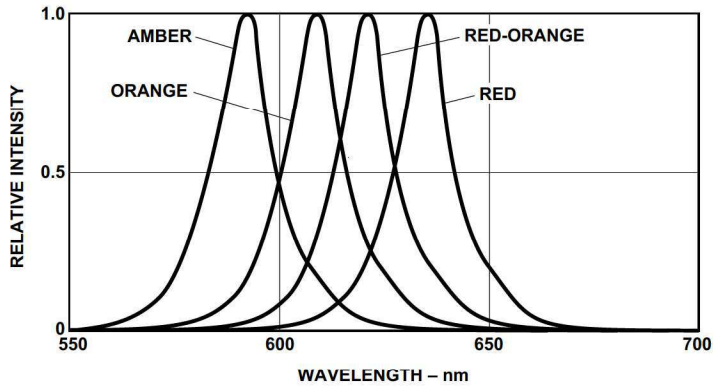

Figure 1. Relative Intensity vs. Peak Wavelength.

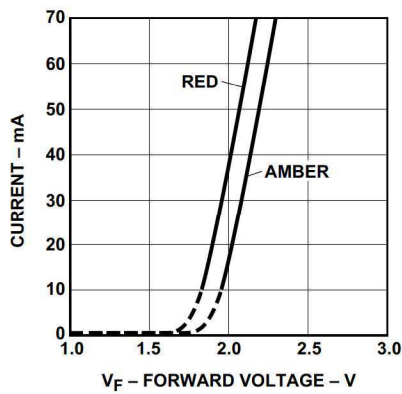

Figure 2. Forward Current vs. Forward Voltage.

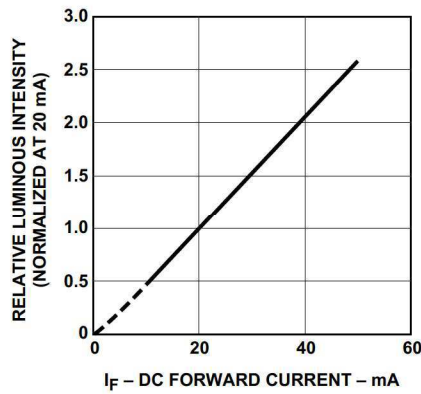

Figure 3. Relative Luminous Intensity vs. Forward Current.

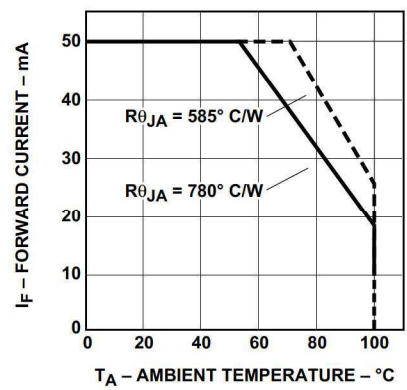

Figure 4. Maximum Forward Current vs. Ambient Temperature. Derating Based on  $T_{JMAX} = 130^\circ\text{C}$ .

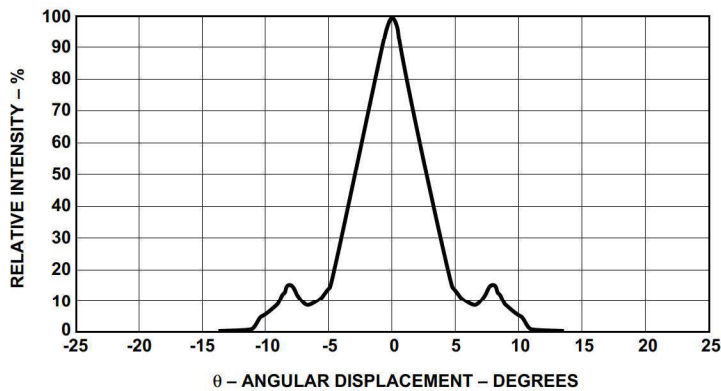

Figure 5. Representative Spatial Radiation Pattern for 6° Viewing Angle Lamps.

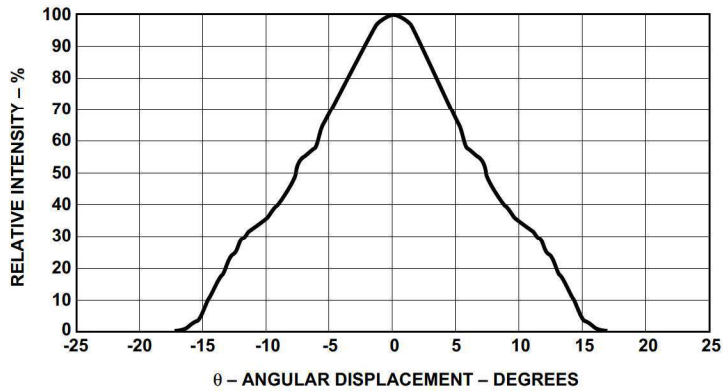

Figure 6. Representative Spatial Radiation Pattern for 15° Viewing Angle Lamps.

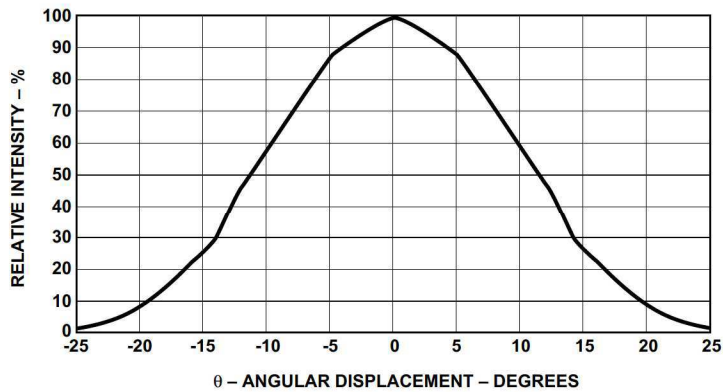

Figure 7. Representative Spatial Radiation Pattern for 23° Viewing Angle Lamps.

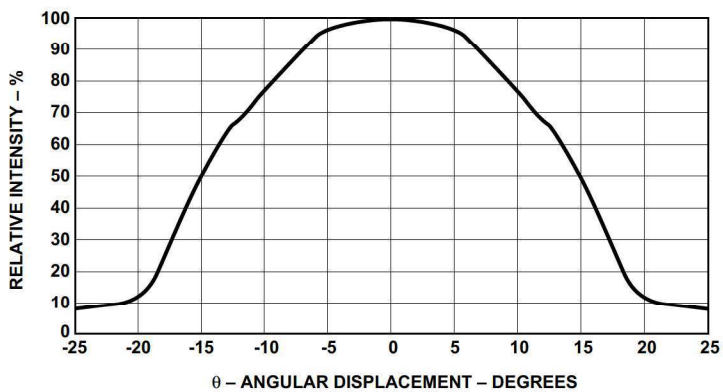

Figure 8. Representative Spatial Radiation Pattern for 30° Viewing Angle Lamps.

For technical assistance or the location of your nearest Hewlett-Packard sales office, distributor or representative call:

**Americas/Canada:** 1-800-235-0312 or 408-654-8675

**Far East/Australasia:** (65) 290-6305

**Japan:** (81 3) 3335-8152

**Europe:** Call your local HP sales office.

Data subject to change.

Copyright © 1997 Hewlett-Packard Co.

Obsoletes 5965-5265E

Printed in U.S.A. 5965-6807E (1/97)