

CX-5F

SMD

■Features

- Compact, thin. (11.8×5.5×2.5mm)
- For self-loading.
- Ceramic package leadless type.
- Emboss tapping.
- Reflow soldering.
- The oscillation circuit can obtain sufficient output at the inverter stage.

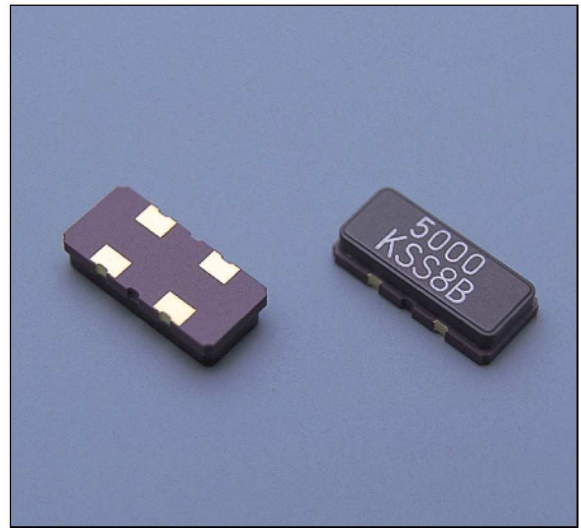

■Specifications

Type		CX-5F	
Frequency Range		3.5~60MHz	
Standard Frequency		Table 1	Table 2
Overtone Order		3.5~29MHz : Fundamental 29~60MHz : 3rd O.T.	
Operating Temp. Range		-10~+70°C	
Storage Temp. Range		-40~+85°C	
Frequency Tolerance	at 25°C	±15, ±30, ±50×10 ⁻⁶	
	Over The Oper. Temp. Range	±15, ±30, ±50×10 ⁻⁶ (referred to 25°C)	
Load Capacitance		Table 1	12pF
Equivalent Series Resistance		3.5~ 3.999MHz 300Ω MAX. 12.0~28.999MHz 100Ω MAX. 4.0~ 7.999MHz 200Ω MAX. 29~60MHz 150Ω MAX. 8.0~11.999MHz 120Ω MAX.	
Drive Level		0.3mW MAX.	
Shock		ΔF/F : ±10×10 ⁻⁶ Three drops onto a hard wood board from the height of 20cm	
Vibration		ΔF/F : ±10×10 ⁻⁶ 10~55Hz, amplitude 1.5mm, each to 3 directions, 2 hours each	

* Taping item packaging : one unit 1,000pcs

■Table 1 Standard Frequencies

Frequency (MHz)	Load capacitance (pF)	Equivalent Series Resistance (ΩMAX.)
3.579545	Series/16	300
4.433619	Series/16	200
14.31818	Series/12	100
17.734476	Series/12	100

■Table 2 Standard Frequencies (MHz)

3.579545	14.31818
3.6864	16.000
4.000	16.9344
6.000	19.6608
8.000	20.000
12.000	

* Please inquire about frequencies other than the above.

■Outline

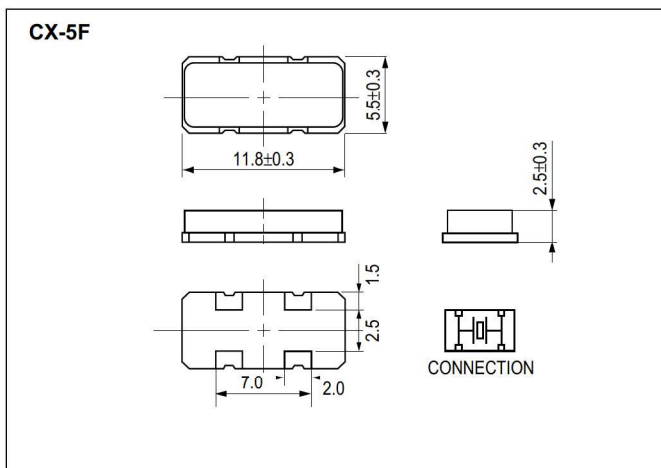

■Land Pattern(reference)

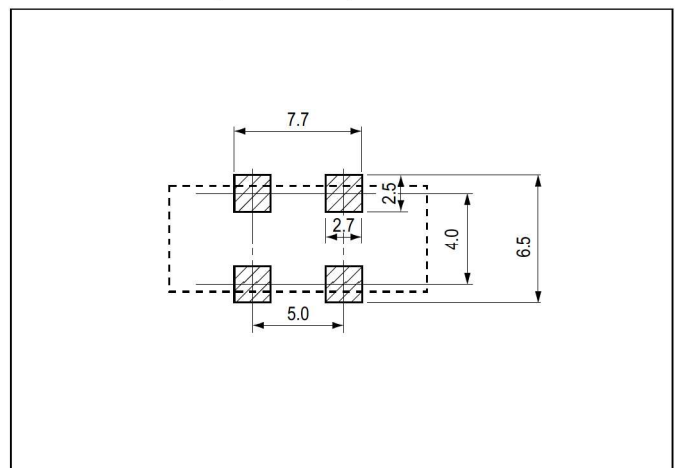

Dimensions(mm)