

### R $\times$ 5VL SERIES

#### OUTLINE

The R $\times$ 5VL Series are voltage detector ICs with high detector threshold accuracy and ultra-low supply current by CMOS process. Each of these ICs consists of a voltage reference unit, a comparator, resistors for voltage detection, an output driver and a hysteresis circuit.

The detector threshold is fixed with high accuracy.

Two output Types, Nch open drain type and CMOS type, are available.

Three types of packages, TO-92, SOT-89 (Mini-power Mold), SOT-23-5 (Mini-mold), are available.

#### FEATURES

- Ultra-low Supply Current.....TYP. 1.0 $\mu$ A (V<sub>DD</sub>=3.0V)
- Broad Operating Voltage Range.....1.5V to 10.0V
- Detector Threshold.....Stepwise setting with a step of 0.1V in the range of  
2.0V to 6.0V is possible (refer to Selection Guide).
- High Accuracy Detector Threshold ..... $\pm$ 2.5%
- Low Temperature-Drift Coefficient of Detector Threshold .....TYP.  $\pm$ 100ppm/ $^{\circ}$ C
- Two Output Types.....Nch Open Drain and CMOS
- Three Types of Packages.....TO-92, SOT-89 (Mini-power Mold), SOT-23-5 (Mini-mold)

#### APPLICATIONS

- CPU & Logic Circuit Reset
- Battery Checker
- Window Comparator
- Wave Shaping Circuit
- Battery Back-Up Circuit
- Power Failure Detector

## BLOCK DIAGRAMS

• Nch Open Drain Output (R×5VL×A)

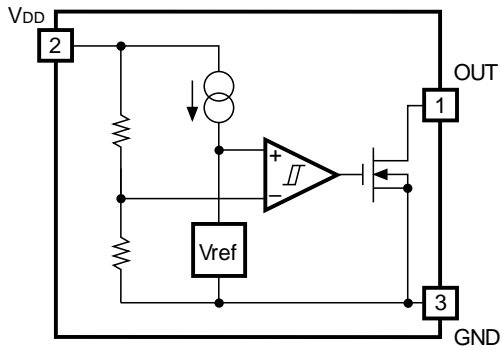

• CMOS Output (R×5VL×C)

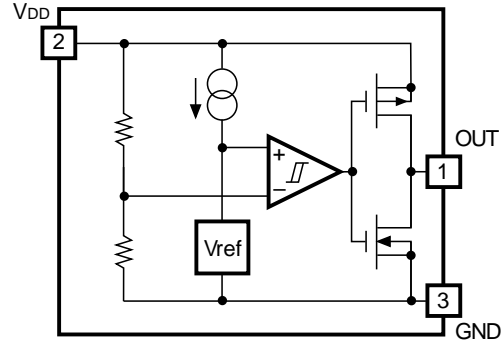

## TIME CHART

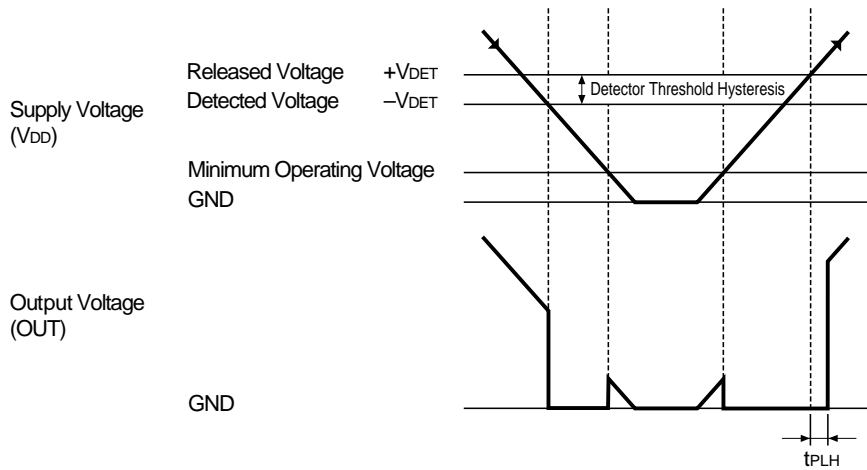

## DEFINITION OF OUTPUT DELAY TIME tPLH

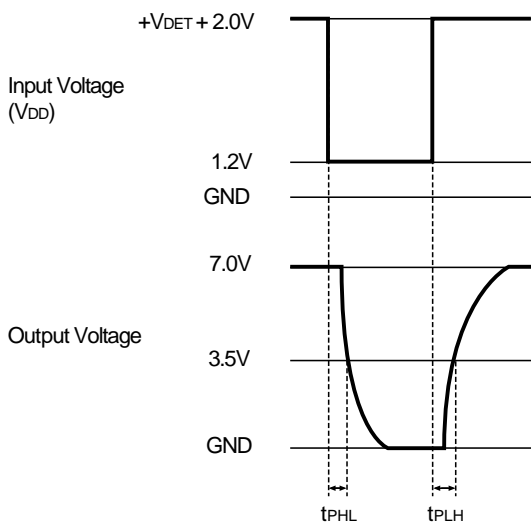

Nch Open Drain Output

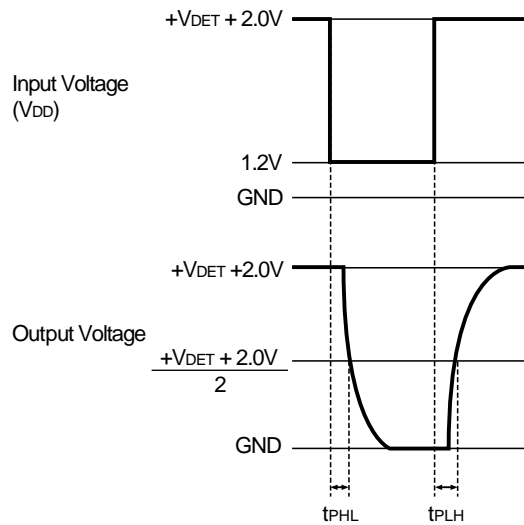

CMOS Output

Output Delay Time  $t_{PLH}$  is defined as follows:

1. In the case of Nch Open Drain Output:

When the time at which a pulse voltage which increases from 1.2V to  $+V_{DET}+2.0V$  is applied to VDD is Time A, and the time at which the output reaches 3.5V under the conditions that the output pin (OUT) is pulled up to 7V by a resistor of 100k $\Omega$  is Time B, the time period from Time A through Time B.

2. In the case of CMOS Output:

When the time at which a pulse voltage which increases from 1.2V to  $+V_{DET} +2.0V$  is applied to VDD is Time A, and the time at which the output voltage reaches the voltage of  $(+V_{DET}+2.0V)/2$  is Time B, the time period from Time A through Time B.

## SELECTION GUIDE

The package type, the detector threshold, the output type, the packing type, and the taping type of R5VL series can be designated at the user's request by specifying the part number as follows:

R5VLxxx-xx ← Part Number  
 ↑     ↑ ↑↑     ↑  
 a     b cd     e

| Code | Contents  |
|------|---|
| a    | Designation of Package Type:<br>E: TO-92<br>H: SOT-89 (Mini-power Mold)<br>N: SOT-23-5 (Mini-mold)  |
| b    | Setting Detector Threshold (-VDET):<br>Stepwise setting with a step of 0.1V in the range of 2.0V to 6.0V is possible.   |
| c    | Designation of Output Type:<br>A: Nch Open Drain<br>C: CMOS   |
| d    | Designation of Packing Type:<br>A: Taping<br>C: Antistatic bag for TO-92 and samples  |
| e    | Designation of Taping Type:<br>Ex. TO-92: RF, RR, TZ<br>SOT-89: T1, T2<br>SOT-23-5: TR, TL<br>(refer to Taping Specifications)<br>"TZ", "T1" and "TR" are prescribed as a standard. |

For example, the product with Package Type SOT-89, Detector Threshold 3.5V, Output Type Nch Open Drain and Taping Type T1, is designated by Part Number RH5VL35AA-T1.

## PIN CONFIGURATION

• TO-92

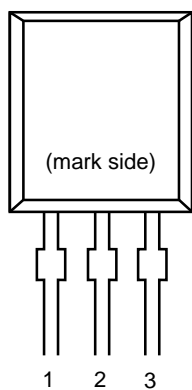

• SOT-89

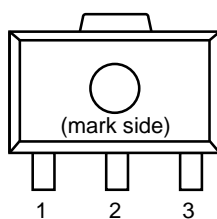

• SOT-23-5

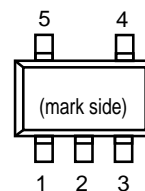

## PIN DESCRIPTION

• TO-92

| Pin No | Symbol |
|--------|--------|
| 1      | OUT    |
| 2      | VDD    |
| 3      | GND    |

• SOT-89

| Pin No | Symbol |
|--------|--------|
| 1      | OUT    |
| 2      | VDD    |
| 3      | GND    |

• SOT-23-5

| Pin No | Symbol |
|--------|--------|
| 1      | OUT    |
| 2      | VDD    |
| 3      | GND    |
| 4      | NC     |
| 5      | NC     |

**ABSOLUTE MAXIMUM RATINGS**T<sub>opt</sub>=25°C

| Symbol              | Item                         | Rating      |  | Unit |
|---------------------|------------------------------|-------------|--|------|
| VDD                 | Supply Voltage               | 12          |  | V    |
| VOUT                | Output Voltage               | CMOS        | V <sub>SS</sub> -0.3 to V <sub>DD</sub> +0.3 | V    |
|                     |                              | Nch         | V <sub>SS</sub> -0.3 to 12                   |      |
| IOUT                | Output Current               | 70          |  | mA   |
| PD1                 | Power Dissipation 1 (NOTE1)  | 300         |  | mW   |
| PD2                 | Power Dissipation 2 (NOTE2)  | 150         |  | mW   |
| T <sub>opt</sub>    | Operating Temperature Range  | -30 to +80  |  | °C   |
| T <sub>stg</sub>    | Storage Temperature Range    | -55 to +125 |  | °C   |
| T <sub>solder</sub> | Lead Temperature (Soldering) | 260°C,10s   |  |      |

(NOTE 1) applied to SOT-89 and TO-92

(NOTE 2) applied to SOT-23-5

**ABSOLUTE MAXIMUM RATINGS**

Absolute Maximum ratings are threshold limit values that must not be exceeded even for an instant under any conditions. Moreover, such values for any two items must not be reached simultaneously. Operation above these absolute maximum ratings may cause degradation or permanent damage to the device. These are stress ratings only and do not necessarily imply functional operation below these limits.

## ELECTRICAL CHARACTERISTICS

### • R5VL20C

T<sub>opt</sub>=25°C

| Symbol                                   | Item                                       | Conditions   | MIN.  | TYP.  | MAX.  | Unit   |
|--|--|--|-------|-------|-------|--------|
| -V <sub>DET</sub>                        | Detector Threshold                         |  | 1.950 | 2.000 | 2.050 | V      |
| V <sub>HYS</sub>                         | Detector Threshold Hysteresis              |  | 0.060 | 0.100 | 0.140 | V      |
| I <sub>SS</sub>                          | Supply Current                             | V <sub>DD</sub> =1.90V                                 |       | 0.90  | 2.70  | μA     |
|  |  | V <sub>DD</sub> =4.00V                                 |       | 1.10  | 3.30  |        |
|  |  | V <sub>DD</sub> =10.0V                                 |       | 1.70  | 5.10  |        |
| V <sub>DD</sub>                          | Operating Voltage                          |  | 1.50  |       | 10.0  | V      |
| I <sub>OUT</sub>                         | Output Current                             | Nch<br>V <sub>DS</sub> =0.5V<br>V <sub>DD</sub> =1.5V  | 0.25  | 0.50  |       | mA     |
|  |  | Pch<br>V <sub>DS</sub> =-2.1V<br>V <sub>DD</sub> =4.5V | 1.00  | 2.00  |       | mA     |
| t <sub>PLH</sub>                         | Output Delay Time                          |  |       |       | 100   | μs     |
| $\frac{\Delta -V_{DET}}{\Delta T_{opt}}$ | Detector Threshold Temperature Coefficient | -30°C ≤ T <sub>opt</sub> ≤ 80°C                        |       | ±100  |       | ppm/°C |

### • R5VL27C

T<sub>opt</sub>=25°C

| Symbol                                   | Item                                       | Conditions   | MIN.  | TYP.  | MAX.  | Unit   |
|--|--|--|-------|-------|-------|--------|
| -V <sub>DET</sub>                        | Detector Threshold                         |  | 2.633 | 2.700 | 2.767 | V      |
| V <sub>HYS</sub>                         | Detector Threshold Hysteresis              |  | 0.081 | 0.135 | 0.189 | V      |
| I <sub>SS</sub>                          | Supply Current                             | V <sub>DD</sub> =2.60V                                 |       | 0.90  | 2.70  | μA     |
|  |  | V <sub>DD</sub> =4.70V                                 |       | 1.10  | 3.30  |        |
|  |  | V <sub>DD</sub> =10.0V                                 |       | 1.70  | 5.10  |        |
| V <sub>DD</sub>                          | Operating Voltage                          |  | 1.50  |       | 10.0  | V      |
| I <sub>OUT</sub>                         | Output Current                             | Nch<br>V <sub>DS</sub> =0.5V<br>V <sub>DD</sub> =1.5V  | 0.25  | 0.50  |       | mA     |
|  |  | Nch<br>V <sub>DS</sub> =0.5V<br>V <sub>DD</sub> =2.0V  | 1.50  | 3.00  |       | mA     |
|  |  | Pch<br>V <sub>DS</sub> =-2.1V<br>V <sub>DD</sub> =4.5V | 1.00  | 2.00  |       | mA     |
| t <sub>PLH</sub>                         | Output Delay Time                          |  |       |       | 100   | μs     |
| $\frac{\Delta -V_{DET}}{\Delta T_{opt}}$ | Detector Threshold Temperature Coefficient | -30°C ≤ T <sub>opt</sub> ≤ 80°C                        |       | ±100  |       | ppm/°C |

• R5VL36C

T<sub>opt</sub>=25°C

| Symbol                                   | Item                                       | Conditions   | MIN.  | TYP.  | MAX.  | Unit   |
|--|--|--|-------|-------|-------|--------|
| -V <sub>DET</sub>                        | Detector Threshold                         |  | 3.510 | 3.600 | 3.690 | V      |
| V <sub>HYS</sub>                         | Detector Threshold Hysteresis              |  | 0.108 | 0.180 | 0.252 | V      |
| I <sub>SS</sub>                          | Supply Current                             | V <sub>DD</sub> =3.47V                                 |       | 1.00  | 3.00  | μA     |
|  |  | V <sub>DD</sub> =5.60V                                 |       | 1.20  | 3.60  |        |
|  |  | V <sub>DD</sub> =10.0V                                 |       | 1.70  | 5.10  |        |
| V <sub>DD</sub>                          | Operating Voltage                          |  | 1.50  |       | 10.0  | V      |
| I <sub>OUT</sub>                         | Output Current                             | Nch<br>V <sub>DS</sub> =0.5V<br>V <sub>DD</sub> =1.5V  | 0.25  | 0.50  |       | mA     |
|  |  | Nch<br>V <sub>DS</sub> =0.5V<br>V <sub>DD</sub> =3.0V  | 3.00  | 5.00  |       | mA     |
|  |  | Pch<br>V <sub>DS</sub> =-2.1V<br>V <sub>DD</sub> =4.5V | 1.00  | 2.00  |       | mA     |
| t <sub>PLH</sub>                         | Output Delay Time                          |  |       |       | 100   | μs     |
| $\frac{\Delta -V_{DET}}{\Delta T_{opt}}$ | Detector Threshold Temperature Coefficient | -30°C ≤ T <sub>opt</sub> ≤ 80°C                        |       | ±100  |       | ppm/°C |

• R5VL45C

T<sub>opt</sub>=25°C

| Symbol                                   | Item                                       | Conditions   | MIN.  | TYP.  | MAX.  | Unit   |
|--|--|--|-------|-------|-------|--------|
| -V <sub>DET</sub>                        | Detector Threshold                         |  | 4.388 | 4.500 | 4.612 | V      |
| V <sub>HYS</sub>                         | Detector Threshold Hysteresis              |  | 0.135 | 0.225 | 0.315 | V      |
| I <sub>SS</sub>                          | Supply Current                             | V <sub>DD</sub> =4.34V                                 |       | 1.10  | 3.30  | μA     |
|  |  | V <sub>DD</sub> =6.50V                                 |       | 1.30  | 3.90  |        |
|  |  | V <sub>DD</sub> =10.0V                                 |       | 1.70  | 5.10  |        |
| V <sub>DD</sub>                          | Operating Voltage                          |  | 1.50  |       | 10.0  | V      |
| I <sub>OUT</sub>                         | Output Current                             | Nch<br>V <sub>DS</sub> =0.5V<br>V <sub>DD</sub> =1.5V  | 0.25  | 0.50  |       | mA     |
|  |  | Nch<br>V <sub>DS</sub> =0.5V<br>V <sub>DD</sub> =4.0V  | 4.00  | 6.00  |       | mA     |
|  |  | Pch<br>V <sub>DS</sub> =-2.1V<br>V <sub>DD</sub> =8.0V | 1.50  | 3.00  |       | mA     |
| t <sub>PLH</sub>                         | Output Delay Time                          |  |       |       | 100   | μs     |
| $\frac{\Delta -V_{DET}}{\Delta T_{opt}}$ | Detector Threshold Temperature Coefficient | -30°C ≤ T <sub>opt</sub> ≤ 80°C                        |       | ±100  |       | ppm/°C |



## • R5VL54C

T<sub>opt</sub>=25°C

| Symbol                                  | Item  | Conditions   | MIN.  | TYP.  | MAX.  | Unit   |
|---|---|--|-------|-------|-------|--------|
| -V <sub>DET</sub>                       | Detector Threshold                            |  | 5.265 | 5.400 | 5.535 | V      |
| V <sub>HYS</sub>                        | Detector Threshold Hysteresis                 |  | 0.162 | 0.270 | 0.378 | V      |
| I <sub>SS</sub>                         | Supply Current                                | V <sub>DD</sub> =5.20V                                 |       | 1.20  | 3.60  | μA     |
|   |   | V <sub>DD</sub> =7.40V                                 |       | 1.40  | 4.20  |        |
|   |   | V <sub>DD</sub> =10.0V                                 |       | 1.70  | 5.10  |        |
| V <sub>DD</sub>                         | Operating Voltage                             |  | 1.50  |       | 10.0  | V      |
| I <sub>OUT</sub>                        | Output Current                                | Nch<br>V <sub>DS</sub> =0.5V<br>V <sub>DD</sub> =1.5V  | 0.25  | 0.50  |       | mA     |
|   |   | Nch<br>V <sub>DS</sub> =0.5V<br>V <sub>DD</sub> =5.0V  | 5.00  | 7.00  |       | mA     |
|   |   | Pch<br>V <sub>DS</sub> =-2.1V<br>V <sub>DD</sub> =8.0V | 1.50  | 3.00  |       | mA     |
| t <sub>PLH</sub>                        | Output Delay Time                             |  |       |       | 100   | μs     |
| $\frac{\Delta-V_{DET}}{\Delta T_{opt}}$ | Detector Threshold<br>Temperature Coefficient | -30°C ≤ T <sub>opt</sub> ≤ 80°C                        |       | ±100  |       | ppm/°C |

## ELECTRICAL CHARACTERISTICS BY DETECTOR THRESHOLD

• R5VLxA

| Part Number | Detector Threshold    |       |       | Detector Threshold Hysteresis |                             | Supply Current 1                                    |      |      | Supply Current 2                                   |      |      | Supply Current 3           |      |      |
|-------------|-----------------------|-------|-------|-------------------------------|-----------------------------|---|------|------|--|------|------|----------------------------|------|------|
|             | -V <sub>DET</sub> (V) |       |       | V <sub>HYS</sub> (V)          |                             | I <sub>SS</sub> ( $\mu$ A)                          |      |      | I <sub>SS</sub> ( $\mu$ A)                         |      |      | I <sub>SS</sub> ( $\mu$ A) |      |      |
|             | MIN.                  | TYP.  | MAX.  | MIN.                          | MAX.                        | Conditions  | TYP. | MAX. | Conditions   | TYP. | MAX. | Conditions                 | TYP. | MAX. |
| R5VL20A     | 1.950                 | 2.000 | 2.050 | (-V <sub>DET</sub> )<br>×3%   | (-V <sub>DET</sub> )<br>×7% | V <sub>DD</sub> =<br>(-V <sub>DET</sub> )<br>-0.10V | 0.9  | 2.7  | V <sub>DD</sub> =<br>(-V <sub>DET</sub> )<br>+2.0V | 1.1  | 3.3  | V <sub>DD</sub> =<br>10V   | 1.7  | 5.1  |
| R5VL21A     | 2.048                 | 2.100 | 2.152 |                               |                             |   |      |      |  |      |      |                            |      |      |
| R5VL22A     | 2.145                 | 2.200 | 2.255 |                               |                             |   |      |      |  |      |      |                            |      |      |
| R5VL23A     | 2.243                 | 2.300 | 2.357 |                               |                             |   |      |      |  |      |      |                            |      |      |
| R5VL24A     | 2.340                 | 2.400 | 2.460 |                               |                             |   |      |      |  |      |      |                            |      |      |
| R5VL25A     | 2.438                 | 2.500 | 2.562 |                               |                             |   |      |      |  |      |      |                            |      |      |
| R5VL26A     | 2.535                 | 2.600 | 2.665 |                               |                             |   |      |      |  |      |      |                            |      |      |
| R5VL27A     | 2.633                 | 2.700 | 2.767 |                               |                             |   |      |      |  |      |      |                            |      |      |
| R5VL28A     | 2.730                 | 2.800 | 2.870 |                               |                             |   |      |      |  |      |      |                            |      |      |
| R5VL29A     | 2.828                 | 2.900 | 2.972 |                               |                             |   |      |      |  |      |      |                            |      |      |
| R5VL30A     | 2.925                 | 3.000 | 3.075 |                               |                             |   |      |      |  |      |      |                            |      |      |
| R5VL31A     | 3.023                 | 3.100 | 3.177 |                               |                             |   |      |      |  |      |      |                            |      |      |
| R5VL32A     | 3.120                 | 3.200 | 3.280 |                               |                             |   |      |      |  |      |      |                            |      |      |
| R5VL33A     | 3.218                 | 3.300 | 3.382 |                               |                             |   |      |      |  |      |      |                            |      |      |
| R5VL34A     | 3.315                 | 3.400 | 3.485 |                               |                             |   |      |      |  |      |      |                            |      |      |
| R5VL35A     | 3.413                 | 3.500 | 3.587 |                               |                             |   |      |      |  |      |      |                            |      |      |
| R5VL36A     | 3.510                 | 3.600 | 3.690 |                               |                             |   |      |      |  |      |      |                            |      |      |
| R5VL37A     | 3.608                 | 3.700 | 3.792 |                               |                             |   |      |      |  |      |      |                            |      |      |
| R5VL38A     | 3.705                 | 3.800 | 3.895 |                               |                             |   |      |      |  |      |      |                            |      |      |
| R5VL39A     | 3.803                 | 3.900 | 3.997 |                               |                             |   |      |      |  |      |      |                            |      |      |
| R5VL40A     | 3.900                 | 4.000 | 4.100 |                               |                             |   |      |      |  |      |      |                            |      |      |
| R5VL41A     | 3.998                 | 4.100 | 4.202 |                               |                             |   |      |      |  |      |      |                            |      |      |
| R5VL42A     | 4.095                 | 4.200 | 4.305 |                               |                             |   |      |      |  |      |      |                            |      |      |
| R5VL43A     | 4.193                 | 4.300 | 4.407 |                               |                             |   |      |      |  |      |      |                            |      |      |
| R5VL44A     | 4.290                 | 4.400 | 4.510 |                               |                             |   |      |      |  |      |      |                            |      |      |
| R5VL45A     | 4.388                 | 4.500 | 4.612 |                               |                             |   |      |      |  |      |      |                            |      |      |
| R5VL46A     | 4.485                 | 4.600 | 4.715 |                               |                             |   |      |      |  |      |      |                            |      |      |
| R5VL47A     | 4.583                 | 4.700 | 4.817 |                               |                             |   |      |      |  |      |      |                            |      |      |
| R5VL48A     | 4.680                 | 4.800 | 4.920 |                               |                             |   |      |      |  |      |      |                            |      |      |
| R5VL49A     | 4.778                 | 4.900 | 5.022 |                               |                             |   |      |      |  |      |      |                            |      |      |
| R5VL50A     | 4.875                 | 5.000 | 5.125 |                               |                             |   |      |      |  |      |      |                            |      |      |
| R5VL51A     | 4.973                 | 5.100 | 5.227 |                               |                             |   |      |      |  |      |      |                            |      |      |
| R5VL52A     | 5.070                 | 5.200 | 5.330 |                               |                             |   |      |      |  |      |      |                            |      |      |
| R5VL53A     | 5.168                 | 5.300 | 5.432 |                               |                             |   |      |      |  |      |      |                            |      |      |
| R5VL54A     | 5.265                 | 5.400 | 5.535 |                               |                             |   |      |      |  |      |      |                            |      |      |
| R5VL55A     | 5.363                 | 5.500 | 5.637 |                               |                             |   |      |      |  |      |      |                            |      |      |
| R5VL56A     | 5.460                 | 5.600 | 5.740 |                               |                             |   |      |      |  |      |      |                            |      |      |
| R5VL57A     | 5.558                 | 5.700 | 5.842 |                               |                             |   |      |      |  |      |      |                            |      |      |
| R5VL58A     | 5.655                 | 5.800 | 5.945 |                               |                             |   |      |      |  |      |      |                            |      |      |
| R5VL59A     | 5.753                 | 5.900 | 6.047 |                               |                             |   |      |      |  |      |      |                            |      |      |
|             |                       |       |       |                               |                             |   |      |      |  |      |      |                            |      |      |

T<sub>opt</sub>=25°C

| Output Current 1  |      |      | Output Current 2  |      |      | Output Delay Time     | Operating Voltage   |      | Detector Threshold Tempco.                     |      |
|---|------|------|---|------|------|-----------------------|---------------------|------|--|------|
| I <sub>out</sub> (mA)   |      |      | I <sub>out</sub> (mA)   |      |      | t <sub>PLH</sub> (μs) | V <sub>DD</sub> (V) |      | Δ-V <sub>DET</sub> /ΔT <sub>opt</sub> (ppm/°C) |      |
| Conditions  | MIN. | TYP. | Conditions  | MIN. | TYP. | MAX.                  | MIN.                | MAX. | Conditions                                     | TYP. |
| Nch<br><br>V <sub>DS</sub> =<br>0.5V<br><br>V <sub>DD</sub> =<br>1.5V | 0.25 | 0.50 | —   | —    | —    | 100                   | 1.5                 | 10   | -30°C ≤<br>T <sub>opt</sub><br>≤ 80°C          | ±100 |
|   |      |      | Nch<br><br>V <sub>DS</sub> =<br>0.5V<br><br>V <sub>DD</sub> =<br>2.0V | 1.5  | 3.0  |                       |                     |      |  |      |
|   |      |      | Nch<br><br>V <sub>DS</sub> =<br>0.5V<br><br>V <sub>DD</sub> =<br>3.0V | 3.0  | 5.0  |                       |                     |      |  |      |
|   |      |      | Nch<br><br>V <sub>DS</sub> =<br>0.5V<br><br>V <sub>DD</sub> =<br>4.0V | 4.0  | 6.0  |                       |                     |      |  |      |
|   |      |      | Nch<br><br>V <sub>DS</sub> =<br>0.5V<br><br>V <sub>DD</sub> =<br>5.0V | 5.0  | 7.0  |                       |                     |      |  |      |

• R5VLxC

| Part Number | Detector Threshold    |       |       | Detector Threshold Hysteresis |                             | Supply Current 1                                    |      |      | Supply Current 2                                   |      |      | Supply Current 3         |      |      |
|-------------|-----------------------|-------|-------|-------------------------------|-----------------------------|---|------|------|--|------|------|--------------------------|------|------|
|             | -V <sub>DET</sub> (V) |       |       | V <sub>HYS</sub> (V)          |                             | I <sub>SS</sub> (μA)                                |      |      | I <sub>SS</sub> (μA)                               |      |      | I <sub>SS</sub> (μA)     |      |      |
|             | MIN.                  | TYP.  | MAX.  | MIN.                          | MAX.                        | Conditions  | TYP. | MAX. | Conditions   | TYP. | MAX. | Conditions               | TYP. | MAX. |
| R5VL20C     | 1.950                 | 2.000 | 2.050 | (-V <sub>DET</sub> )<br>×3%   | (-V <sub>DET</sub> )<br>×7% | V <sub>DD</sub> =<br>(-V <sub>DET</sub> )<br>-0.10V | 0.9  | 2.7  | V <sub>DD</sub> =<br>(-V <sub>DET</sub> )<br>+2.0V | 1.1  | 3.3  | V <sub>DD</sub> =<br>10V | 1.7  | 5.1  |
| R5VL21C     | 2.048                 | 2.100 | 2.152 |                               |                             |   |      |      |  |      |      |                          |      |      |
| R5VL22C     | 2.145                 | 2.200 | 2.255 |                               |                             |   |      |      |  |      |      |                          |      |      |
| R5VL23C     | 2.243                 | 2.300 | 2.357 |                               |                             |   |      |      |  |      |      |                          |      |      |
| R5VL24C     | 2.340                 | 2.400 | 2.460 |                               |                             |   |      |      |  |      |      |                          |      |      |
| R5VL25C     | 2.438                 | 2.500 | 2.562 |                               |                             |   |      |      |  |      |      |                          |      |      |
| R5VL26C     | 2.535                 | 2.600 | 2.665 |                               |                             |   |      |      |  |      |      |                          |      |      |
| R5VL27C     | 2.633                 | 2.700 | 2.767 |                               |                             |   |      |      |  |      |      |                          |      |      |
| R5VL28C     | 2.730                 | 2.800 | 2.870 |                               |                             |   |      |      |  |      |      |                          |      |      |
| R5VL29C     | 2.828                 | 2.900 | 2.972 |                               |                             |   |      |      |  |      |      |                          |      |      |
| R5VL30C     | 2.925                 | 3.000 | 3.075 |                               |                             |   |      |      |  |      |      |                          |      |      |
| R5VL31C     | 3.023                 | 3.100 | 3.177 |                               |                             |   |      |      |  |      |      |                          |      |      |
| R5VL32C     | 3.120                 | 3.200 | 3.280 |                               |                             |   |      |      |  |      |      |                          |      |      |
| R5VL33C     | 3.218                 | 3.300 | 3.382 |                               |                             |   |      |      |  |      |      |                          |      |      |
| R5VL34C     | 3.315                 | 3.400 | 3.485 |                               |                             |   |      |      |  |      |      |                          |      |      |
| R5VL35C     | 3.413                 | 3.500 | 3.587 |                               |                             |   |      |      |  |      |      |                          |      |      |
| R5VL36C     | 3.510                 | 3.600 | 3.690 |                               |                             |   |      |      |  |      |      |                          |      |      |
| R5VL37C     | 3.608                 | 3.700 | 3.792 |                               |                             |   |      |      |  |      |      |                          |      |      |
| R5VL38C     | 3.705                 | 3.800 | 3.895 |                               |                             |   |      |      |  |      |      |                          |      |      |
| R5VL39C     | 3.803                 | 3.900 | 3.997 |                               |                             |   |      |      |  |      |      |                          |      |      |
| R5VL40C     | 3.900                 | 4.000 | 4.100 |                               |                             |   |      |      |  |      |      |                          |      |      |
| R5VL41C     | 3.998                 | 4.100 | 4.202 |                               |                             |   |      |      |  |      |      |                          |      |      |
| R5VL42C     | 4.095                 | 4.200 | 4.305 |                               |                             |   |      |      |  |      |      |                          |      |      |
| R5VL43C     | 4.193                 | 4.300 | 4.407 |                               |                             |   |      |      |  |      |      |                          |      |      |
| R5VL44C     | 4.290                 | 4.400 | 4.510 |                               |                             |   |      |      |  |      |      |                          |      |      |
| R5VL45C     | 4.388                 | 4.500 | 4.612 |                               |                             |   |      |      |  |      |      |                          |      |      |
| R5VL46C     | 4.485                 | 4.600 | 4.715 |                               |                             |   |      |      |  |      |      |                          |      |      |
| R5VL47C     | 4.583                 | 4.700 | 4.817 |                               |                             |   |      |      |  |      |      |                          |      |      |
| R5VL48C     | 4.680                 | 4.800 | 4.920 |                               |                             |   |      |      |  |      |      |                          |      |      |
| R5VL49C     | 4.778                 | 4.900 | 5.022 |                               |                             |   |      |      |  |      |      |                          |      |      |
| R5VL50C     | 4.875                 | 5.000 | 5.125 |                               |                             |   |      |      |  |      |      |                          |      |      |
| R5VL51C     | 4.973                 | 5.100 | 5.227 |                               |                             |   |      |      |  |      |      |                          |      |      |
| R5VL52C     | 5.070                 | 5.200 | 5.330 |                               |                             |   |      |      |  |      |      |                          |      |      |
| R5VL53C     | 5.168                 | 5.300 | 5.432 |                               |                             |   |      |      |  |      |      |                          |      |      |
| R5VL54C     | 5.265                 | 5.400 | 5.535 |                               |                             |   |      |      |  |      |      |                          |      |      |
| R5VL55C     | 5.363                 | 5.500 | 5.637 |                               |                             |   |      |      |  |      |      |                          |      |      |
| R5VL56C     | 5.460                 | 5.600 | 5.740 |                               |                             |   |      |      |  |      |      |                          |      |      |
| R5VL57C     | 5.558                 | 5.700 | 5.842 |                               |                             |   |      |      |  |      |      |                          |      |      |
| R5VL58C     | 5.655                 | 5.800 | 5.945 |                               |                             |   |      |      |  |      |      |                          |      |      |
| R5VL59C     | 5.753                 | 5.900 | 6.047 |                               |                             |   |      |      |  |      |      |                          |      |      |
|             |                       |       |       |                               |                             |   |      |      |  |      |      |                          |      |      |

Topt=25°C

| Output Current 1 |           |      | Output Current 2 |            |           | Output Current 3 |      |            | Output Delay Time | Operating Voltage |      | Detector Threshold Tempco. |      |
|------------------|-----------|------|------------------|------------|-----------|------------------|------|------------|-------------------|-------------------|------|----------------------------|------|
| Iout(mA)         |           |      | Iout(mA)         |            |           | Iout(mA)         |      |            | tPLH (μs)         | VDD(V)            |      | Δ-VDET/ΔTopt (ppm/°C)      |      |
| Conditions       | MIN.      | TYP. | Conditions       | MIN.       | TYP.      | Conditions       | MIN. | TYP.       | MAX.              | MIN.              | MAX. | Conditions                 | TYP. |
| Nch              | 0.25      | 0.50 | —                | —          | —         | Pch              | 1.0  | 2.0        | 100               | 1.5               | 10   | -30°C ≤ Topt ≤ 80°C        | ±100 |
|                  |           |      | Nch              | VDS= 0.5V  | 1.5       |                  |      |            |                   |                   |      |                            |      |
|                  |           |      | VDD= 2.0V        | Nch        | VDS= 0.5V | 3.0              | 5.0  | VDS= -2.1V |                   |                   |      |                            |      |
|                  |           |      | VDD= 3.0V        |            | VDS= 0.5V | 4.0              | 6.0  | VDS= -2.1V |                   |                   |      |                            |      |
| Nch              | VDS= 0.5V | 5.0  | 7.0              | VDS= -2.1V |           |                  |      |            |                   |                   |      |                            |      |
|                  |           |      |                  |            |           |                  |      |            |                   |                   |      |                            |      |

## OPERATION

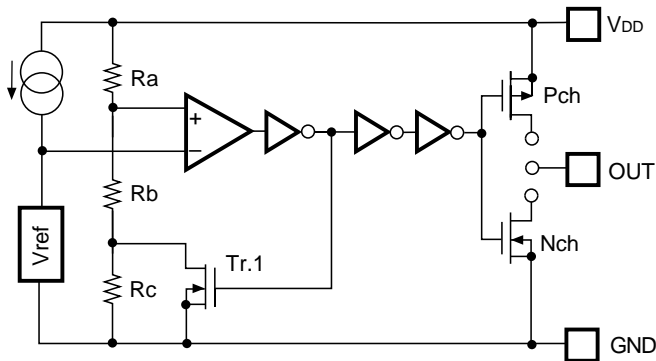

FIG. 1 Block Diagram

- In R5VLxA, Nch Tr. drain is connected to OUT pin.
- In R5VLxC, Nch Tr. drain and Pch Tr. drain are connected to OUT pin.

## Operation Diagram

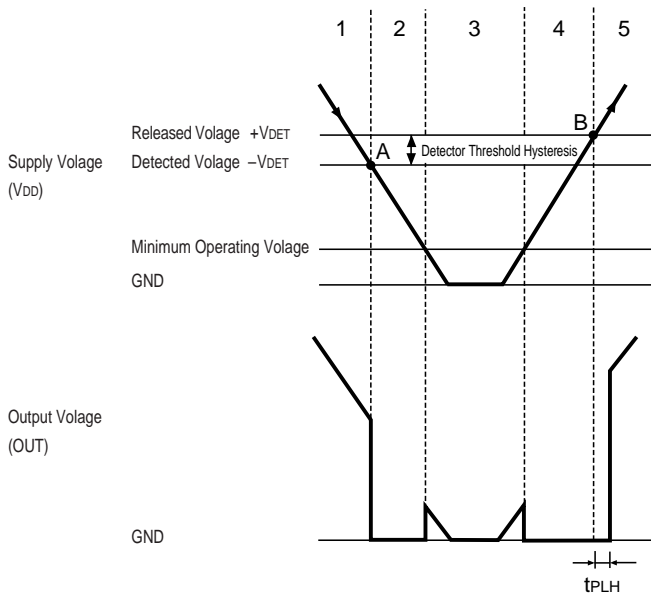

FIG. 2 Operation Diagram

| Step                           | Step 1 | Step 2 | Step 3     | Step 4     | Step 5 |     |
|--------------------------------|--------|--------|------------|------------|--------|-----|
| Comparator(+)Pin Input Voltage | I      | II     | II         | II         | I      |     |
| Comparator Output              | H      | L      | Indefinite | L          | H      |     |
| Tr. 1                          | OFF    | ON     | Indefinite | ON         | OFF    |     |
| Output Tr.                     | Pch    | ON     | OFF        | Indefinite | OFF    | ON  |
|                                | Nch    | OFF    | ON         | Indefinite | ON     | OFF |

$$I. \frac{Rb + Rc}{Ra + Rb + Rc} \cdot V_{DD}$$

$$II. \frac{Rb}{Ra + Rb} \cdot V_{DD}$$

Step 1. Output Voltage is equal to Power Source Voltage ( $V_{DD}$ ).

Step 2. When Input Voltage to Comparator reaches the state of  $V_{ref} \geq V_{DD} \cdot (Rb + Rc) / (Ra + Rb + Rc)$  at Point A (Detected Voltage  $-V_{DET}$ ), the output of Comparator is reserved, so that Output Voltage becomes GND.

Step 3. In the case of CMOS Output, Output Voltage becomes unstable when Supply Voltage ( $V_{DD}$ ) is smaller than Minimum Operating Voltage. In the case of Nch Open Drain Output, a pulled-up voltage is output.

Step 4. Output Voltage becomes equal to GND.

Step 5. When Input Voltage to Comparator reaches the state of  $V_{ref} \leq V_{DD} \cdot (Rb) / (Ra + Rb)$  at Point B (Released Voltage  $+V_{DET}$ ), the output of Comparator is reserved, so that Output Voltage becomes equal to Supply Voltage ( $V_{DD}$ )

## TEST CIRCUITS

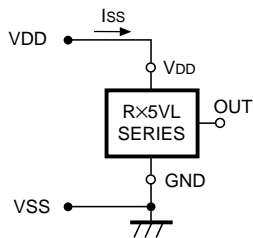

FIG. 3 Supply Current Test Circuit

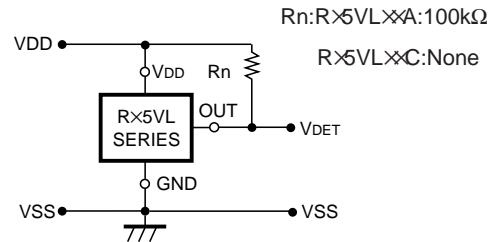

FIG. 4 Detector Threshold Test Circuit

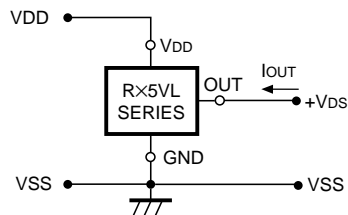

FIG. 5 Nch Driver Output Current Test Circuit

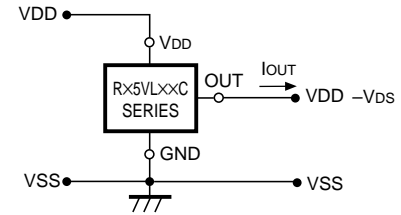

FIG. 6 Pch Driver Output Current Test Circuit

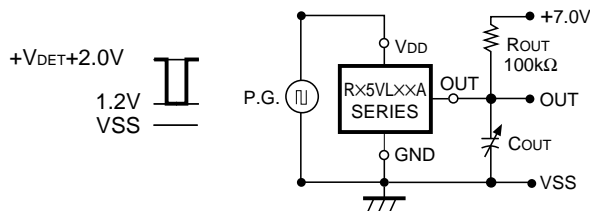
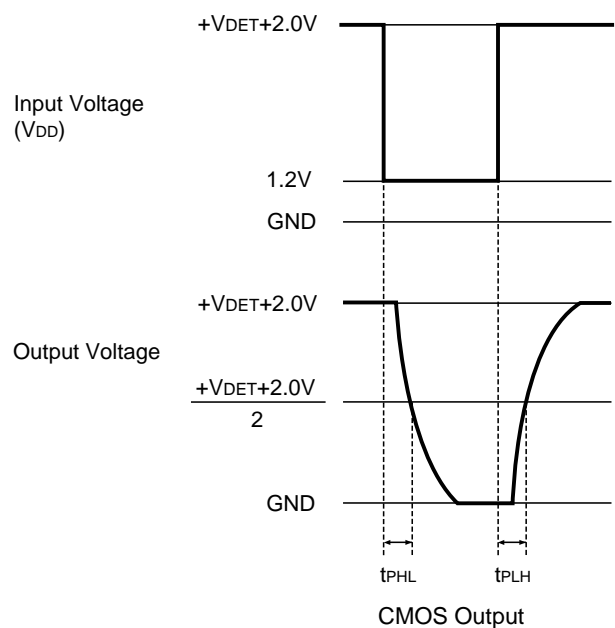
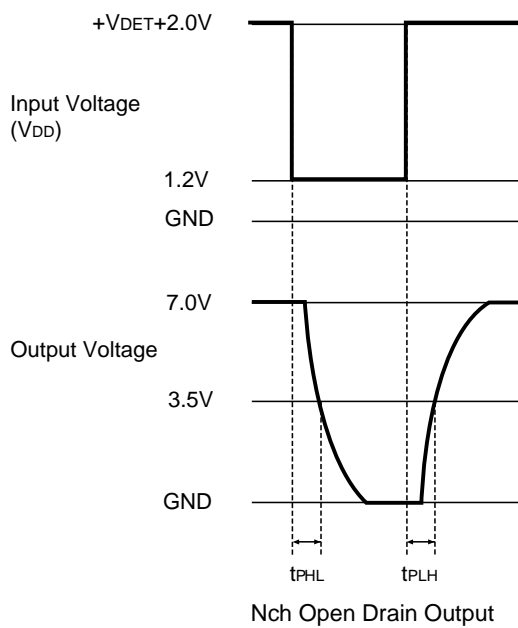

FIG. 7 Output Delay Time Test Circuit

In Output Delay Time Test Circuit in FIG.7, it's Output Voltage Fall Times ( $t_{PHL}$ ) and Rise Times ( $t_{PLH}$ ) are defined as shown below.



## TYPICAL CHARACTERISTICS

### 1) Supply Current vs. Input Voltage

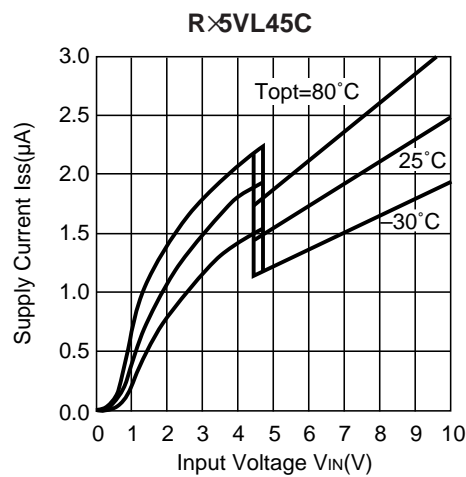
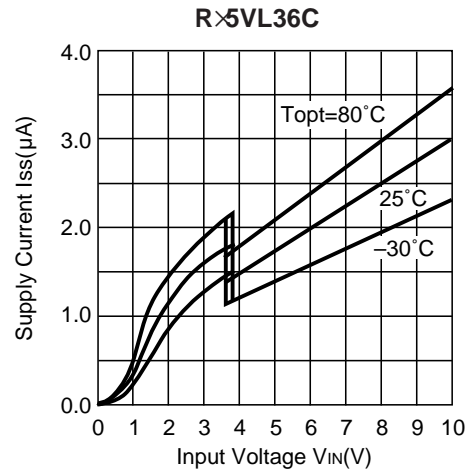
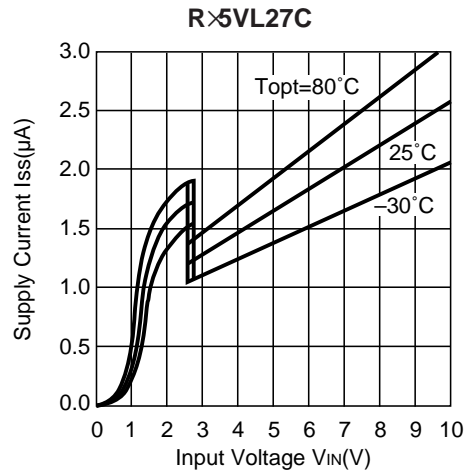

### 2) Detector Threshold vs. Temperature

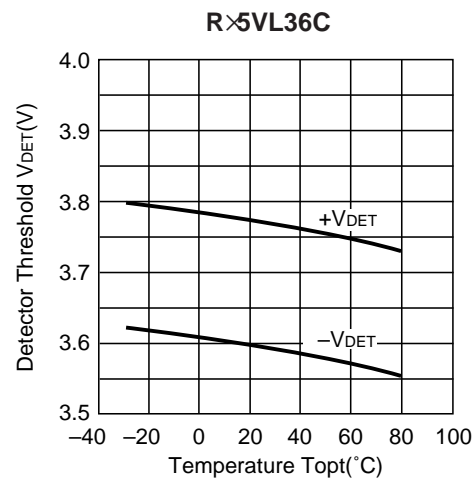
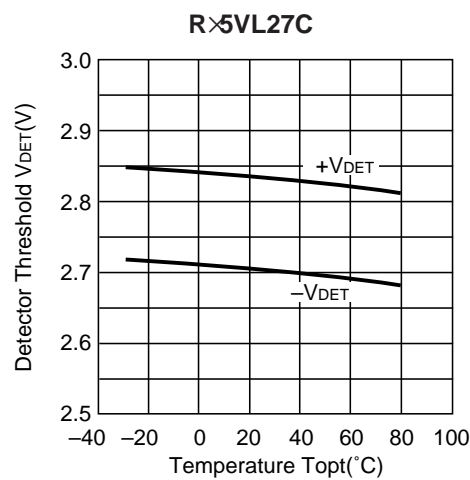



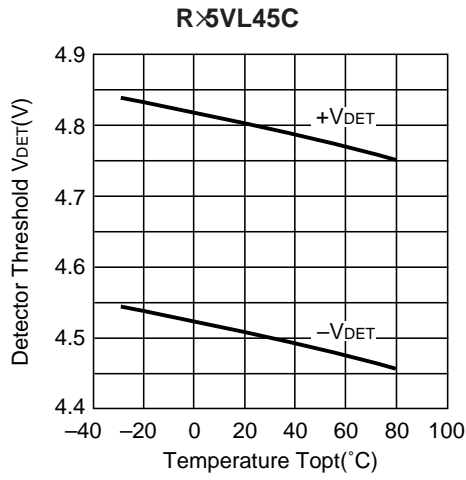

3) Output Voltage vs. Input Voltage

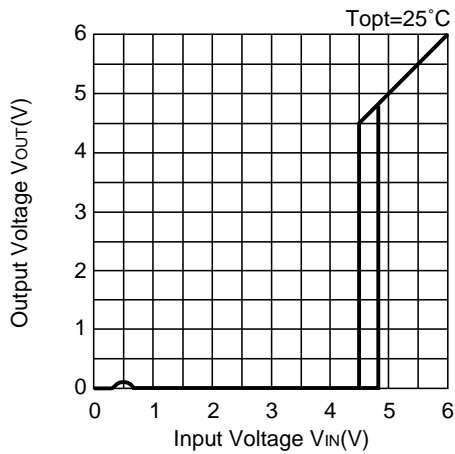
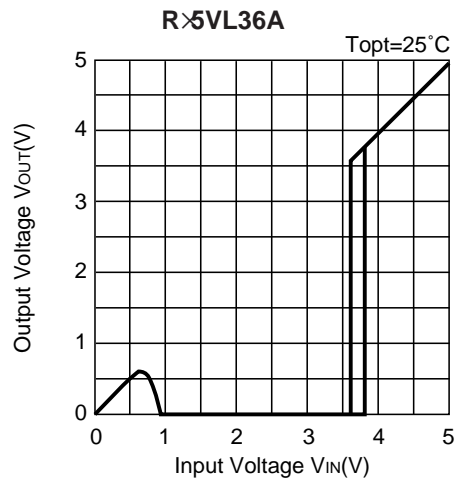
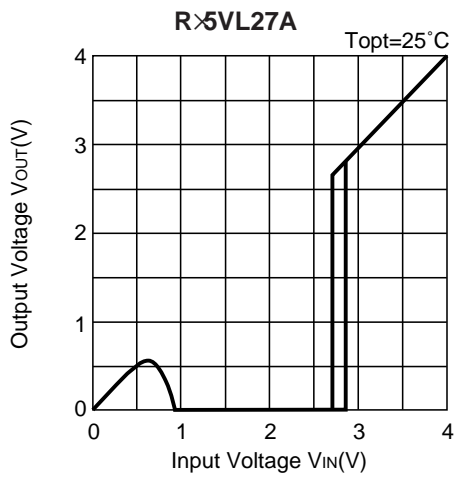

4) Nch Driver Output Current vs. V<sub>ds</sub>

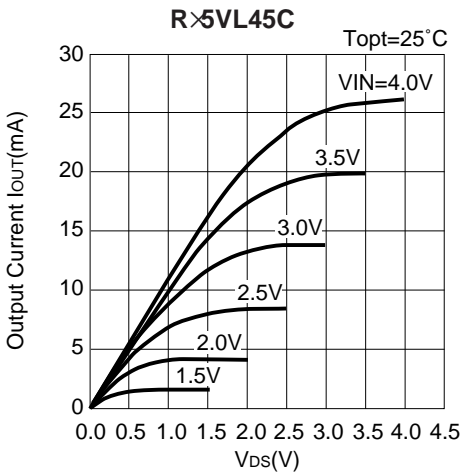
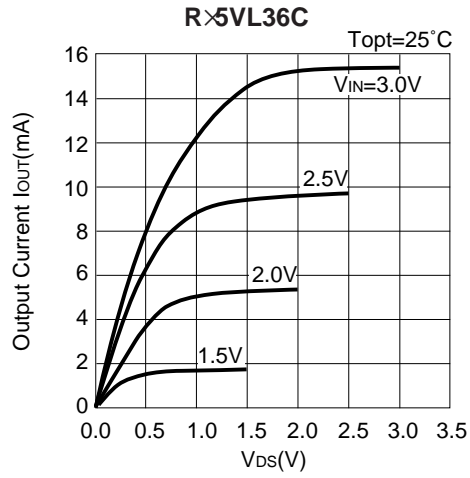
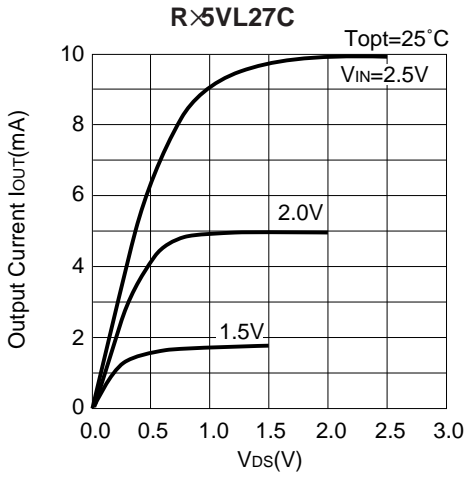

5) Nch Driver Output Current vs. Input Voltage

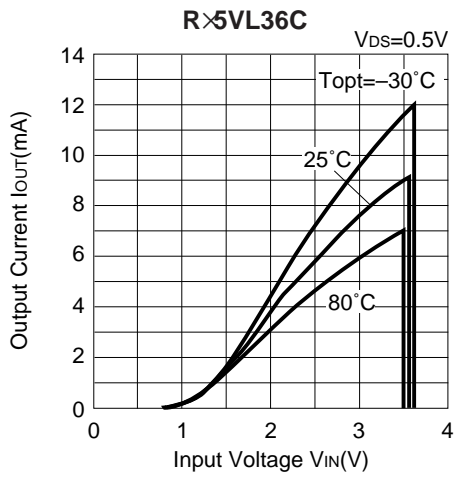
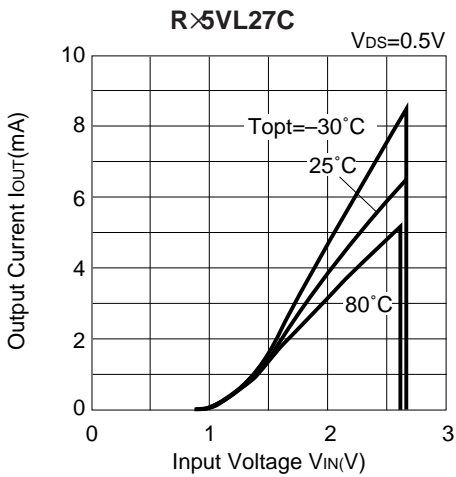

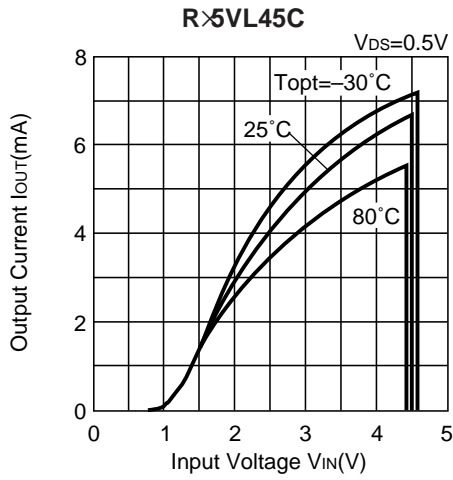

6) Pch Driver Output Current vs. Input Voltage

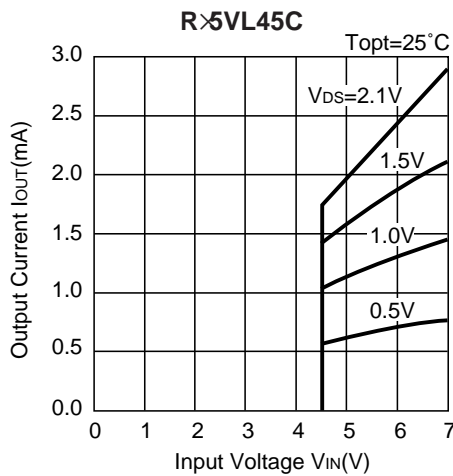
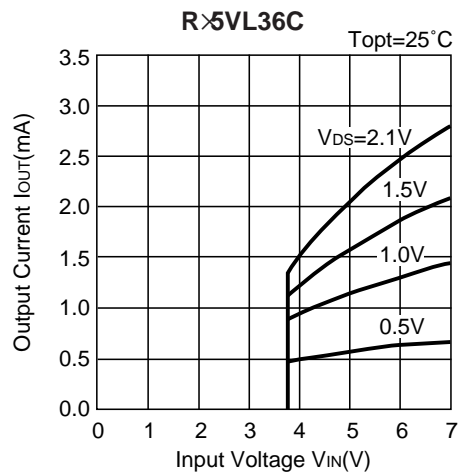
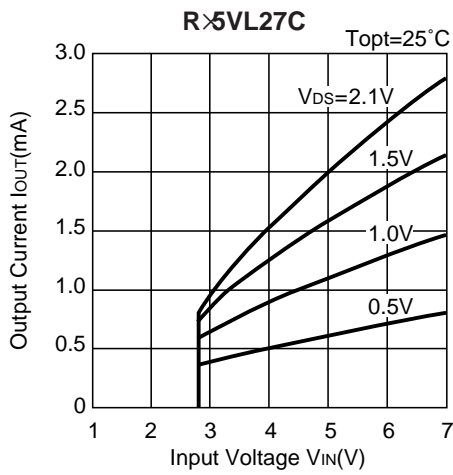

7) Output Delay Time vs. Load Capacitance

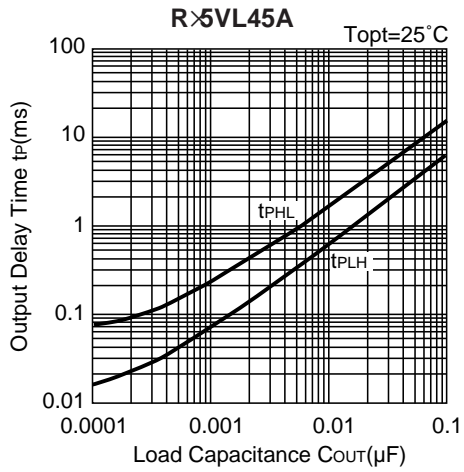
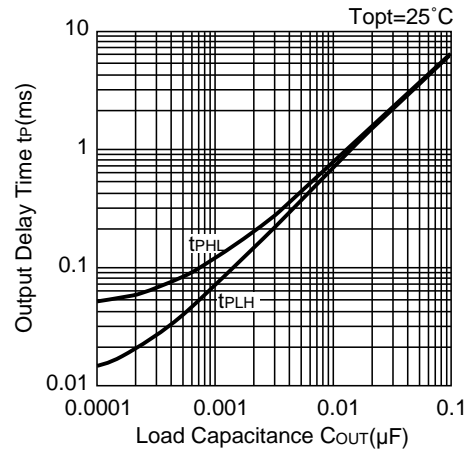
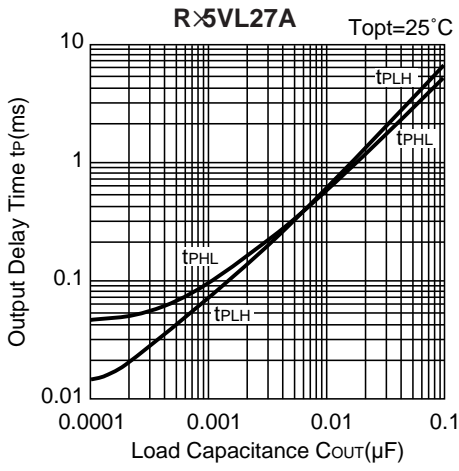

## TYPICAL APPLICATION

### • R5VLxA CPU Reset Circuit (Nch Open Drain Output)

(1) Input Voltage to R5VLxA is the same as the input voltage to CPU.

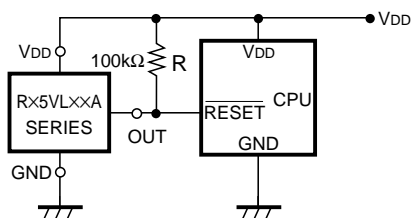

(2) Input Voltage to R5VLxA is different from the input voltage to CPU.

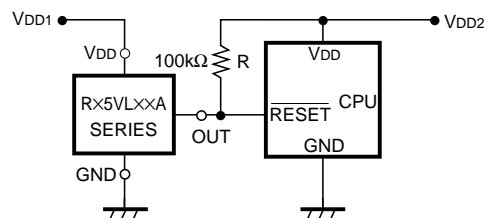

### • R5VLxC CPU Reset Circuit (CMOS Output)

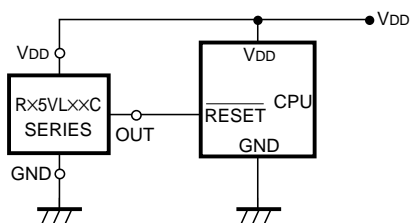

### • R5VLxA Output delay Time Circuit

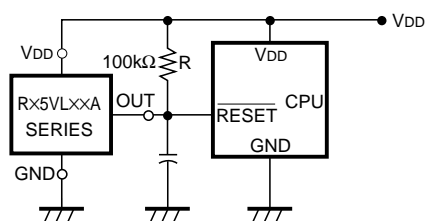

### • Memory Back-up Circuit

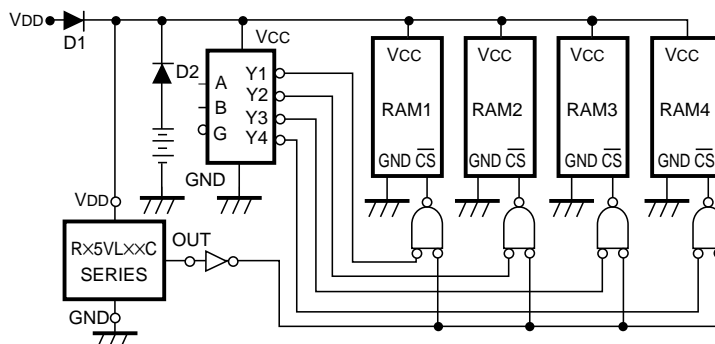

• Voltage Level Indicator Circuit (lighted when the power runs out)  
(Nch Open Drain Output)

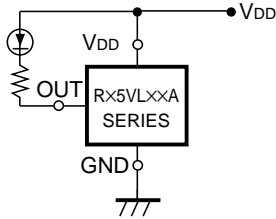

• Detector Threshold Changing Circuit  
(Nch Open Drain Output)

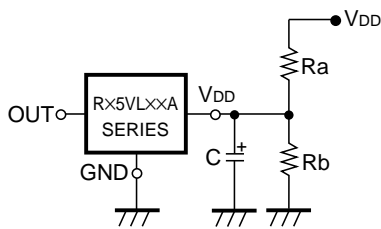

$$\text{Changed Detector Threshold} = \frac{Ra + Rb}{Rb} \cdot (-V_{DET})$$

$$\text{Hysteresis Voltage} = \frac{Ra + Rb}{Rb} \cdot V_{HYS}$$

(Note) Please note that when the value of Ra becomes excessively large, the detector threshold detected may differ from the value calculated by use of the above formula.

• Window Comparator Circuit  
(Nch Open Drain Output)

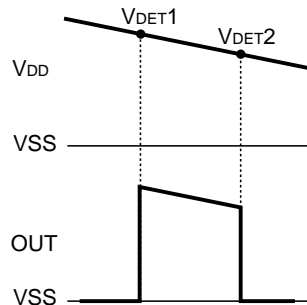
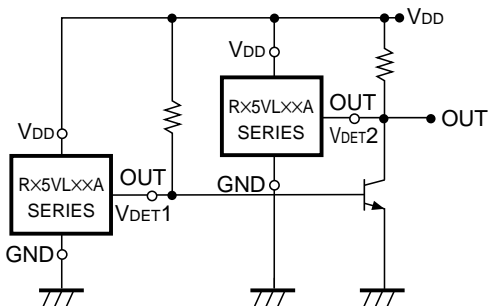

• Excessive Charge Preventing Circuit

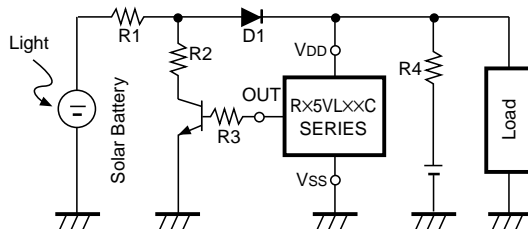

## APPLICATION HINTS

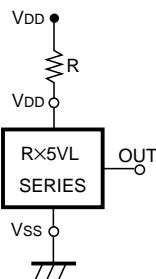

FIG. 8

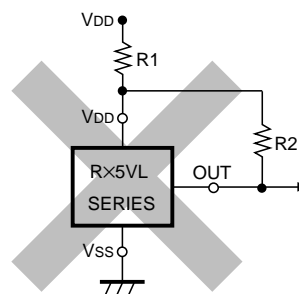
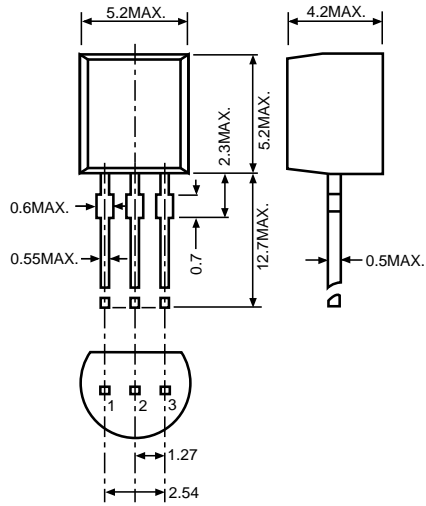

FIG. 9

1. When R5VL×C (CMOS Output) is used in FIG. 8, this IC may oscillate by the through-type current at the detection when impedance is connected between Power Source VDD and R5VL VDD Pin. When R5VL×A (Nch Open Drain Output) is used in FIG. 8, and R becomes excessively large, Detector Threshold may be varied because of the voltage drop of the supply current in the IC itself.
2. The connection as shown in FIG. 9 may cause the oscillation in both R5VL×C (CMOS Output) and R5VL×A (Nch Open Drain Output).

**PACKAGE DIMENSIONS** (Unit: mm)

• TO-92



• SOT-89

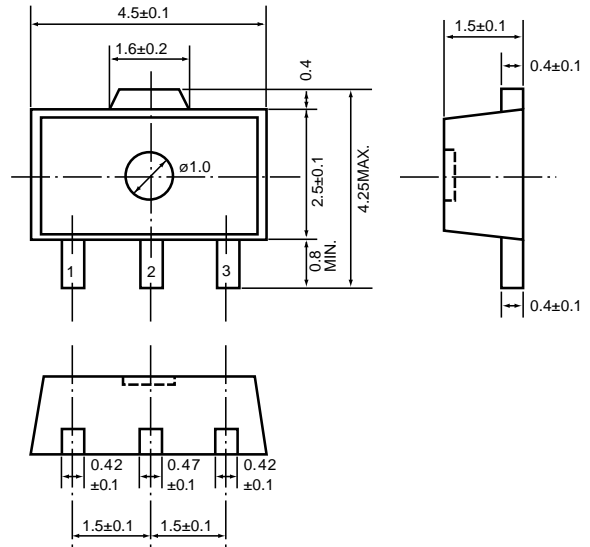

• SOT-23-5

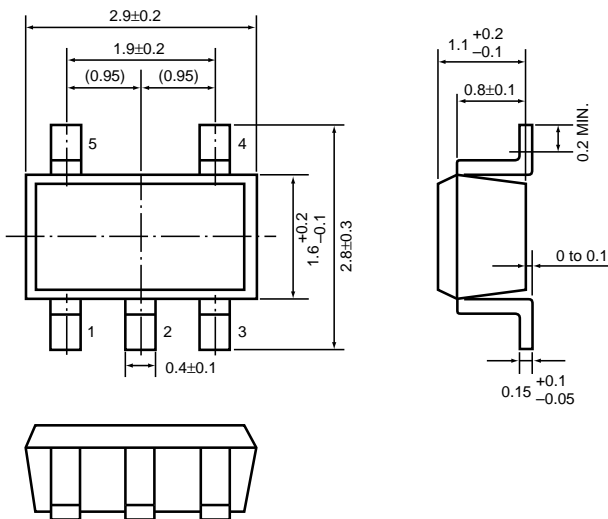



# TAPING SPECIFICATIONS (Unit: mm)

## • TO-92

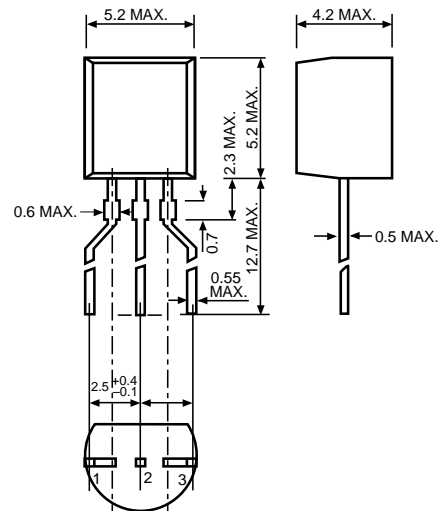
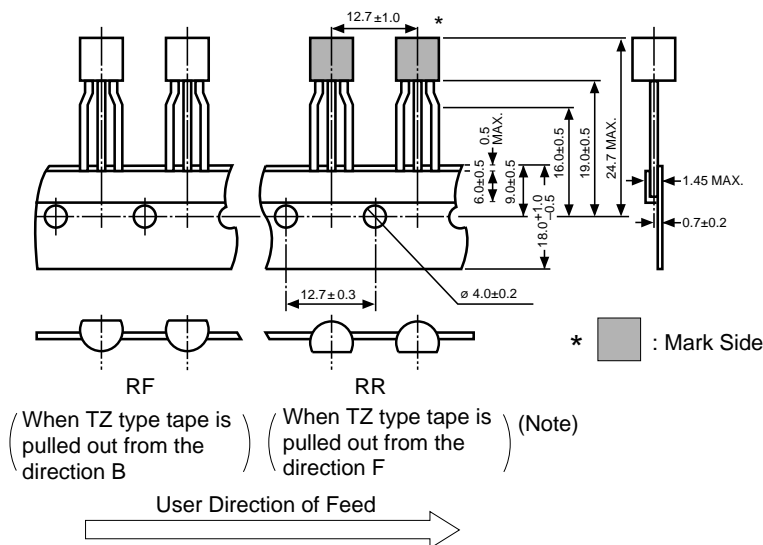

(Note) When taping is conducted, the pins of TO-92 are subjected to a particular forming.

## • SOT-89

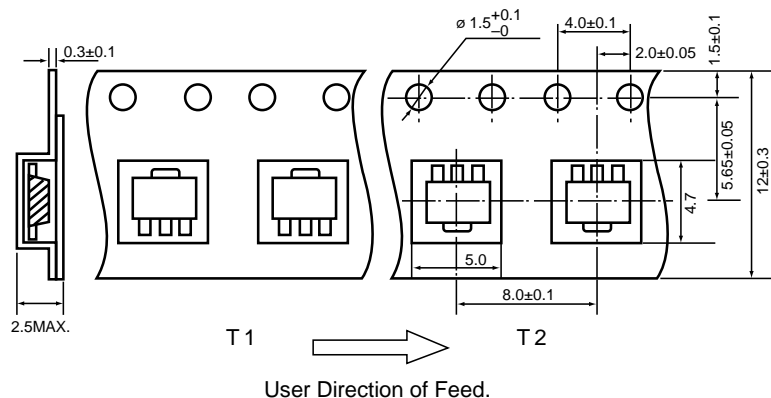

(Note) TZ type tape is not in the form of a reel, but is packed in a zigzag state in a box. Therefore, the tape can be used as either an RF type tape or an RR type tape, depending upon the pulling out direction (B or F).

## • SOT-23-5

