

PN313

PIN Photodiode

For optical control systems

■ Features

- Fast response which is well suited to high speed modulated light detection : $t_r, t_f = 50 \text{ ns}$ (typ.)
- High sensitivity, high reliability
- Peak sensitivity wavelength matched with infrared light emitting diodes : $\lambda_p = 940 \text{ nm}$ (typ.)
- Wide detection area, wide acceptance half angle : $\theta = 65 \text{ deg.}$ (typ.)
- Adoption of visible light cutoff resin

■ Absolute Maximum Ratings ($T_a = 25^\circ\text{C}$)

Parameter	Symbol	Ratings	Unit
Reverse voltage (DC)	V_R	30	V
Power dissipation	P_D	100	mW
Operating ambient temperature	T_{opr}	-30 to +80	$^\circ\text{C}$
Storage temperature	T_{stg}	-40 to +80	$^\circ\text{C}$

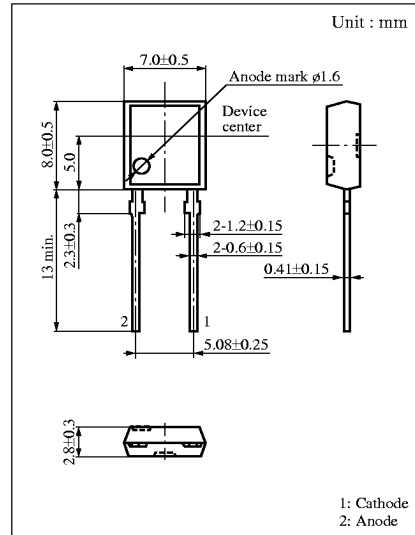

■ Electro-Optical Characteristics ($T_a = 25^\circ\text{C}$)

Parameter	Symbol	Conditions	min	typ	max	Unit
Dark current	I_D	$V_R = 10\text{V}$		5	50	nA
Photo current	I_L	$V_R = 10\text{V}, L = 1000 \text{ lx}^{*1}$	35	50		μA
Peak sensitivity wavelength	λ_p	$V_R = 10\text{V}$		940		nm
Response time	t_r, t_f^{*2}	$V_R = 10\text{V}, R_L = 1\text{k}\Omega$		50		ns
Response time	t_r, t_f^{*2}	$V_R = 10\text{V}, R_L = 100\text{k}\Omega$		5		μs
Capacitance between pins	C_t	$V_R = 0\text{V}, f = 1\text{MHz}$		70		pF
Acceptance half angle	θ	Measured from the optical axis to the half power point		65		deg.

*1 Measurements were made using a tungsten lamp (color temperature $T = 2856\text{K}$) as a light source.

*2 Switching time measurement circuit

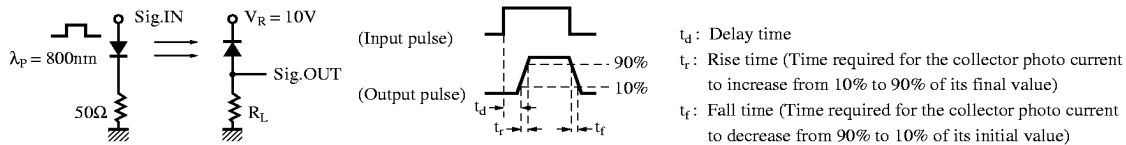

t_d : Delay time
 t_r : Rise time (Time required for the collector photo current to increase from 10% to 90% of its final value)
 t_f : Fall time (Time required for the collector photo current to decrease from 90% to 10% of its initial value)

