

8-BIT NMOS D/A CONVERTER

The μ PD7011 is a low cost 8-bit NMOS digital-to-analog converter using Enhancement Depletion (ED) technology. The μ PD7011 features single +5 V power supply operation and on board voltage reference.

The serial interface option allows easy interface to the μ COM-87, and -75 series of single chip microcomputers and the μ PD7720 Signal Processing chip (SPI). In parallel mode the μ PD7011 is easily connected to the 8080 and 8085 type bus structures by the bus interface facilities.

FEATURES

- E/D NMOS monolithic
- Internal voltage reference
- Serial interface with μ COM-87, -75 and μ PD7720 (SPI)
- Bus interface with 8080 and 8085A-2
- Pure binary and 2's complement code available in serial mode
- Two performance ranges linearity error: μ PD7011C, 1 LSB; μ PD7011C-1, 1/2 LSB
- Single +5 V power supply
- 18-pin plastic DIP (300 mil)

BLOCK DIAGRAM

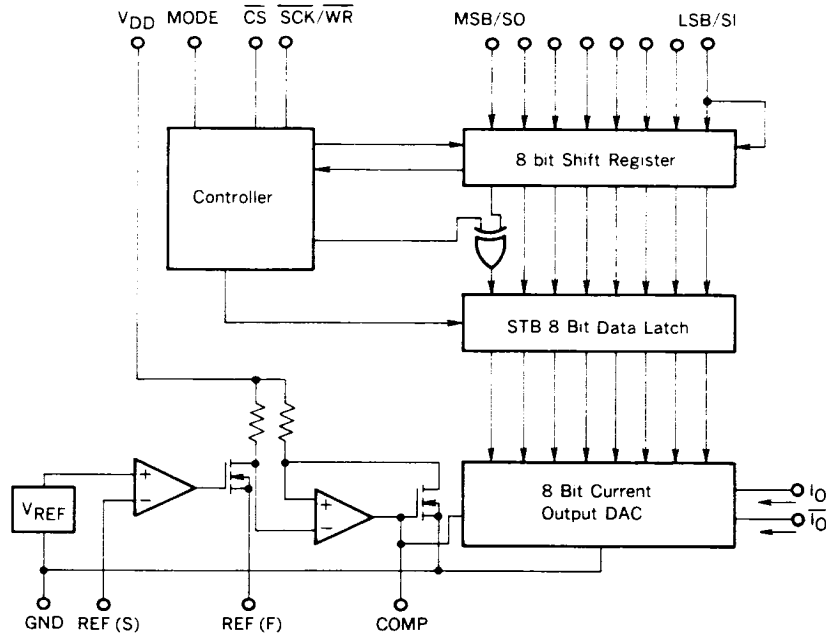

NEC cannot assume any responsibility for any circuits shown or represent that they are free from patent infringement.

CONNECTION DIAGRAM (Top View)

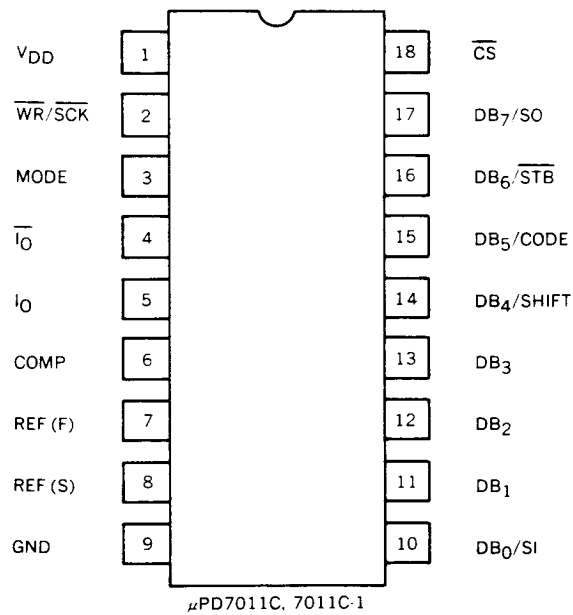

ABSOLUTE MAXIMUM RATINGS ($T_a = 25^\circ\text{C}$)

Operating Temperature	-20 to +70	$^\circ\text{C}$
Storage Temperature	-65 to +150	$^\circ\text{C}$
Power Supply Voltage	-0.3 to +7.0	V
All Input Voltages	-0.3 to $V_{DD} + 0.3$	V
Power Dissipation	300	mW
SO Pin Pull-up Voltage	$V_{DD} + 0.3$	V
I_O/\bar{I}_O Output Pull-up Voltage	+10	V

RECOMMENDED OPERATING CONDITIONS (T_a = +25 °C)

PARAMETER	SYMBOL	LIMITS			UNIT
		MIN.	TYP.	MAX.	
Supply Voltage	V _{DD}	4.75	5.0	5.25	V
Reference Current	I _{REF}	225	250	275	μA
Full-Scale Current	I _{FS}	0.9	1.0	1.1	mA
Reference Force Terminal Voltage	V _{REF(F)}	2.65	2.7	2.75	V
Low-Level Logic Input	V _{IL}	0		0.8	V
High-Level Logic Input	V _{IH}	2.0		V _{DD}	V
Analog Output Pull-up Voltage		2.4		3.0	V
SO Pin 17 Output Pull-up Voltage			V _{DD}		V
Frequency Compensation Capacitor (See Note)	C _{COMP}	0.01	0.1	1.0	μF

Note: Using a frequency compensation capacitor larger than 1 μF will promote low noise operation of the μPD7011C. However, the turn-on time at initial power on will increase.

DC CHARACTERISTICS ($V_{DD} = 5 \pm 0.25$ V, $T_a = 25$ °C, $I_{FS} = 1$ mA, $C_{COMP} = 0.1$ μF)

PARAMETER	SYMBOL	LIMITS			UNIT	TEST CONDITION
		MIN.	TYP.	MAX.		
Resolution		8	8	8	Bits	-20 °C to +70 °C
Nonlinearity, 7011C-1	NL		0.25	0.5	LSB	-20 °C to +70 °C
Nonlinearity, 7011C	NL		0.5	1	LSB	-20 °C to +70 °C
Differential Nonlinearity	DNL		0.1	1.0	LSB	-20 °C to +70 °C
Zero-Scale Error				0.5	LSB	-20 °C to +70 °C
Zero-Scale Symmetry		-1.5	-1.0	-0.5	LSB	Note 1
Gain Error, 7011C-1				3	%FSR	
Gain Error, 7011C				5	%FSR	Note 2
Full-Scale Symmetry		-1.5	-1.0	-0.5	LSB	Note 3
Reference Voltage	$V_{REF(S)}$	1.41	2.0	2.59	V	
Power Supply Current	I_{DD}		7	13	mA	
Logic Input Leakage	I_{LEAK}		0.1	10	μA	$0 \leq V_I \leq V_{DD}$
Low-Level Output Voltage	V_{OL}			0.5	V	SO (Pin 17) $I_{SINK} = 2$ mA
Output Leakage	I_{OH}		0.1	10	μA	SO (Pin 17) $V_O = V_{DD}$
Full-Scale Drift			70		PPM/°C	$\Delta I_O(FS) / \Delta T$
Supply Voltage 7011C-1 Rejection Ratio	SVRR			0.8	%FSR/V	$\Delta I_O(FS) / \Delta T$
Supply Voltage 7011C Rejection Ratio	SVRR			1.2	%FSR/V	$\Delta I_O(FS) / \Delta V_{DD}$
Analog Output Compliance		2.4		8.0	V	$\Delta I_O(FS) \leq 1$ LSB

- Notes:**
1. Zero-scale symmetry is defined as follows:
 $255(I_{O(ZS)} - \overline{I_{O(ZS)}}) / I_{O(FS)}$.
 2. Gain error is defined as follows:
 $100(I_{O(FS)} \times 256 / 255 - 4I_{REF}) / 4I_{REF}$.
 3. Full-scale symmetry is defined as follows:
 $255(I_{O(ZS)} - \overline{I_{O(ZS)}}) / I_{O(FS)}$.

AC RECOMMENDED CONDITIONS ($T_a = 25^\circ\text{C}$, $V_{DD} = 5 \pm 0.25\text{V}$, Note 1)

PARAMETER	SYMBOL	LIMITS			UNIT	TEST CONDITION
		MIN.	TYP.	MAX.		
Serial Mode						
Serial Clock Setup Time	t_{SKCS}	30			ns	$\overline{SCK} \uparrow \rightarrow \overline{CS} \downarrow$
CS Setup Time	t_{SCSK}	300			ns	$\overline{CS} \downarrow \rightarrow \overline{SCK} \uparrow$
Data Setup Time	t_{SIK}	120			ns	$SI \rightarrow \overline{SCK} \uparrow$
Data Hold Time	t_{HKI}	50			ns	$\overline{SCK} \uparrow \rightarrow SI$
High-Level Serial Clock Pulse Width	t_{WHK}	300			ns	
Low-Level Serial Clock Pulse Width	t_{WLK}	300			ns	
Strobe Hold Time	t_{HKST}	100			ns	$\overline{SCK} \uparrow \rightarrow \overline{STB} \uparrow$
High-Level Strobe Pulse Width	t_{WHST}	200			ns	
Low-Level Strobe Pulse Width	t_{WLST}	200			ns	
Chip Select Hold Time	t_{HKCS}	0			ns	$\overline{SCK} \uparrow \rightarrow \overline{CS} \uparrow$
Serial Clock Hold Time	t_{HCSK}	100			ns	$\overline{CS} \uparrow \rightarrow \overline{SCK} \downarrow$
Strobe Setup Time	t_{SSTCS}	300			ns	$\overline{STB} \uparrow \rightarrow \overline{CS} \downarrow$
Parallel Mode						
Address Setup Time	t_{AW}	0			ns	$\overline{CS} \downarrow \rightarrow \overline{WR} \downarrow$
Low-Level WR Pulse Width	t_{WW}	200			ns	
Address Hold Time	t_{WA}	0			ns	$\overline{WR} \uparrow \rightarrow \overline{CS} \uparrow$
Data Setup Time	t_{DW}	180			ns	$DB \rightarrow \overline{WR} \uparrow$
Data Hold Time	t_{WD}	0			ns	$\overline{WR} \uparrow \rightarrow DB$

Note: $t_r, t_f \cong 50\text{ ns}$.

AC CHARACTERISTICS ($T_a = 25^\circ\text{C}$, $V_{DD} = 5\pm 0.25\text{ V}$)

PARAMETER	SYMBOL	LIMITS			UNIT	TEST CONDITION
		MIN.	TYP.	MAX.		
Analog Output Setting Time	t_{SET1}		1	3	μs	Parallel Mode, Note 1
	t_{SET2}		1	3	μs	Serial Mode, Note 2
Serial Data Delay Time	t_{DKO}			450	ns	SCK : - SO, Note 2
Delay Time T_D Floating S_O	t_{FCSO}			250	ns	CS : - S_O , High Impedance

Notes: 1. $R_L = 2\text{ k}\Omega$; $C_L = 20\text{ pF}$.
 2. $R_L = 2\text{ k}\Omega$; $C_L = 20\text{ pF}$.

TIMING CHART

1. Parallel Mode (MODE = L)

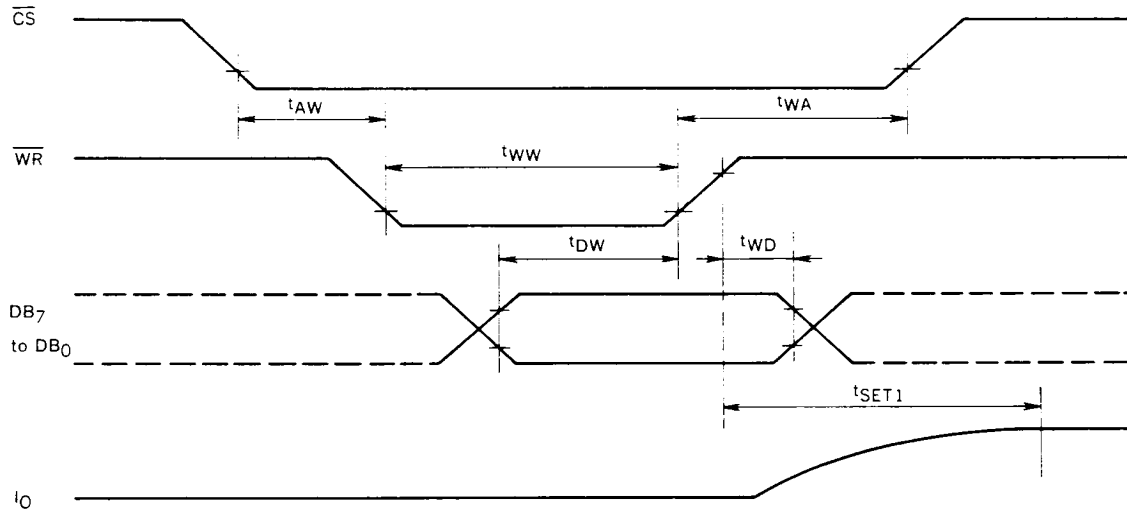

2. Serial Mode (MODE = H)

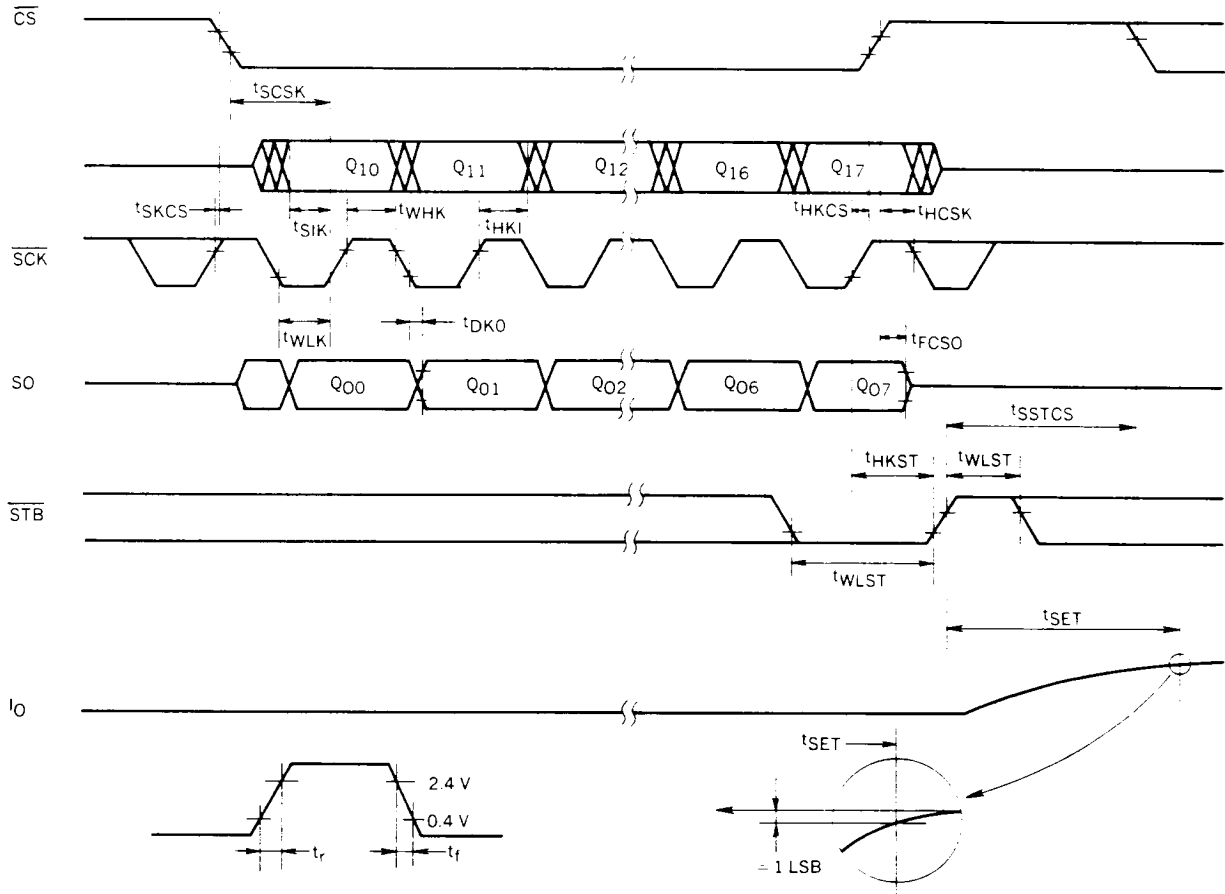

CONTROL BLOCK OPERATION

1. Parallel Mode (MODE = LOW)

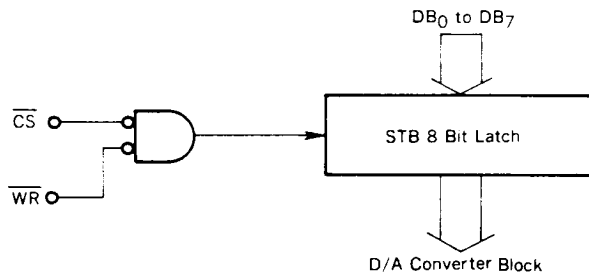

2. Serial Mode, MSB First (SHIFT = MODE = High)

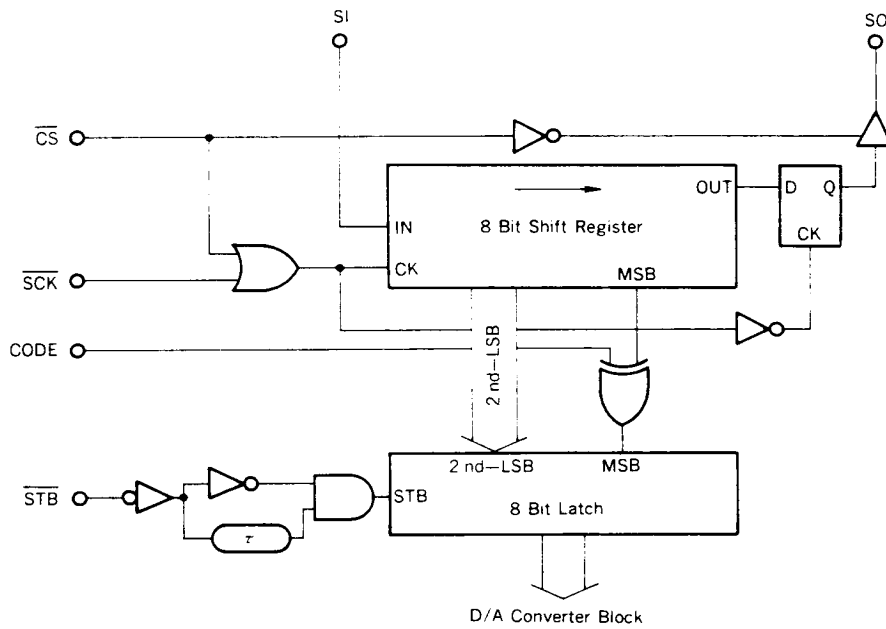

3. Serial Mode, LSB First (SHIFT = Low, MODE = High)

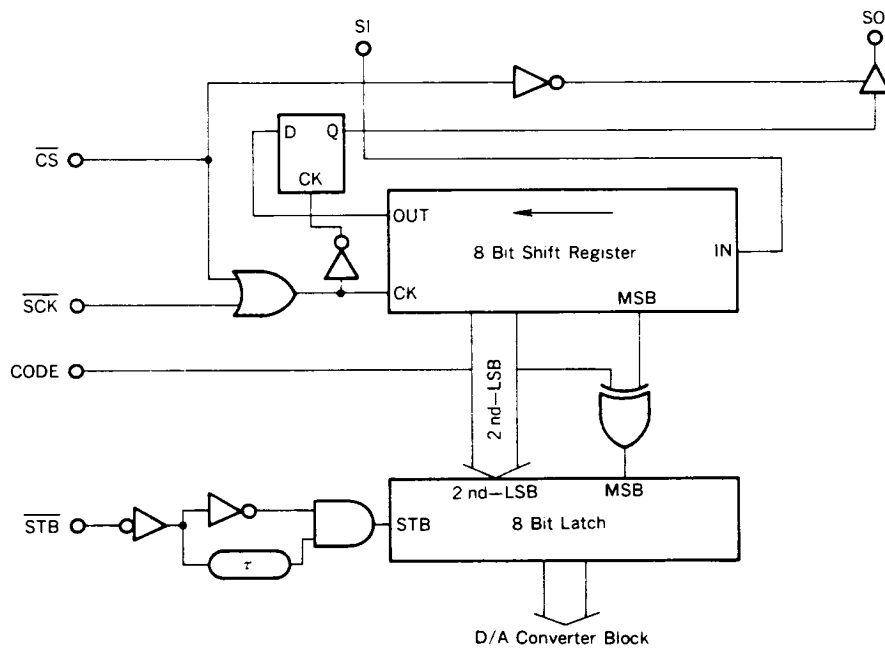

TYPICAL APPLICATIONS

Correction Diagram

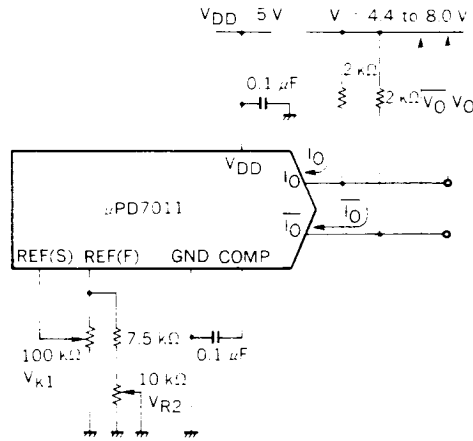

($V_{DD} = 5\text{ V}$, $V^+ = 5\text{ V}$)

Digital Input		I_{OUT}	$\overline{I_{OUT}}$	$V_O(V)$	$\overline{V_O}(V)$
MSB	LSB	(mA)	(mA)		
1	1	0.996	0.004	1.992	0.008
1	1	0.992	0.008	1.984	0.016
⋮	⋮	⋮	⋮	⋮	⋮
1	0	0.504	0.496	1.008	0.992
1	0	0.500	0.500	1.000	1.000
0	1	0.496	0.504	0.992	1.008
⋮	⋮	⋮	⋮	⋮	⋮
0	0	0.004	0.996	0.008	1.992
0	0	0.000	1.000	0.000	2.000

Adjustment Procedure

- a. Set $V_{REF(F)} = 2.7\text{ V}$ by V_{R1}
- b. After latching full-scale digital input, set $V_O = 2.0\text{ V}$ by V_{R2}

- Notes:
1. Both I_O and $\overline{I_O}$ must use pull-up resistors.
 2. Use resistors of 1 % accuracy.
 3. Capacitive load at $V_{REF(F)}$ pin should be less than 15 pF.

(1) $V_{OUT} = 3$ to 5 V, $\overline{V_{OUT}} = 5$ to 3 V

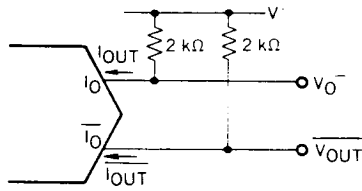

($V_{DD} = V^+ = 5$ V)

Digital Input		I_{OUT}	$\overline{I_{OUT}}$	V_{OUT}	$\overline{V_{OUT}}$
MSB	LSB	(mA)	(mA)	(V)	(V)
1	1	0.996	0.004	3.008	4.992
1	1	0.992	0.008	3.016	4.984
⋮	⋮	⋮	⋮	⋮	⋮
1	0	0.500	0.500	4.000	4.000
⋮	⋮	⋮	⋮	⋮	⋮
0	0	0.004	0.996	4.992	3.008
0	0	0.000	1.000	5.000	3.000

(2) $V_{OUT} = 0$ to 3 V

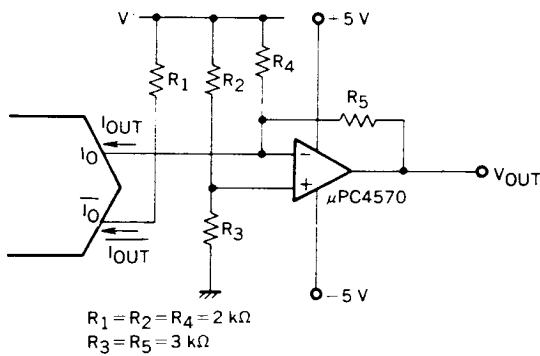

($V_{DD} = V^+ = 5$ V)

Digital Input		I_{OUT}	$\overline{I_{OUT}}$	V_{OUT}
MSB	LSB	(mA)	(mA)	(V)
1	1	0.996	0.004	2.988
1	1	0.992	0.008	2.976
⋮	⋮	⋮	⋮	⋮
1	0	0.500	0.500	1.500
⋮	⋮	⋮	⋮	⋮
0	0	0.004	0.996	0.012
0	0	0.000	1.000	0.000

(3) $V_{OUT} = 0$ to 10 V

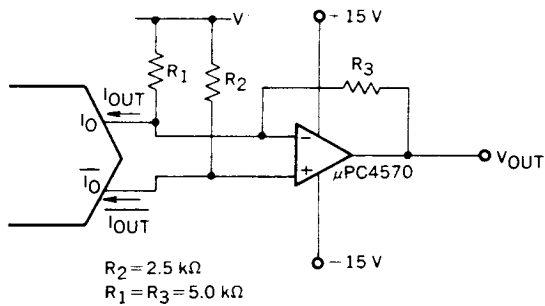

($V_{DD} = V^+ = 5$ V)

Digital Input		I_{OUT}	$\overline{I_{OUT}}$	V_{OUT}
MSB	LSB	(mA)	(mA)	(V)
1	1	0.996	0.004	9.96
1	1	0.992	0.008	9.92
⋮	⋮	⋮	⋮	⋮
1	0	0.500	0.500	5.00
⋮	⋮	⋮	⋮	⋮
0	0	0.004	0.996	0.04
0	0	0.000	1.000	0.00

OPERATING CHARACTERISTICS (T_a = 25 °C)

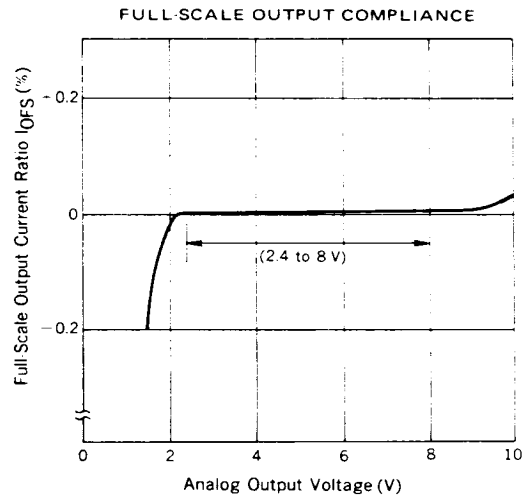
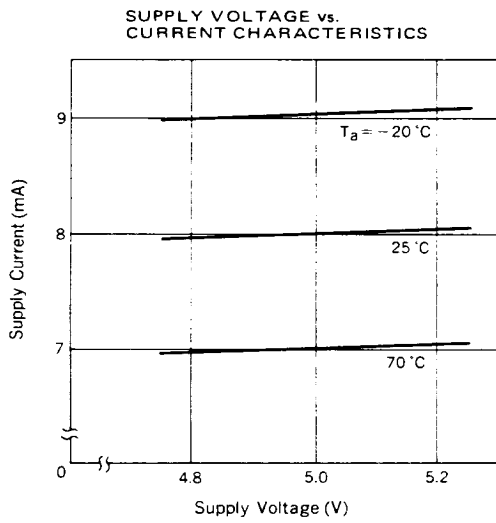
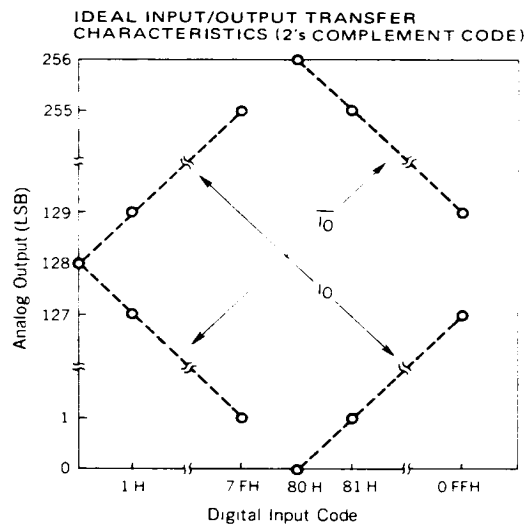
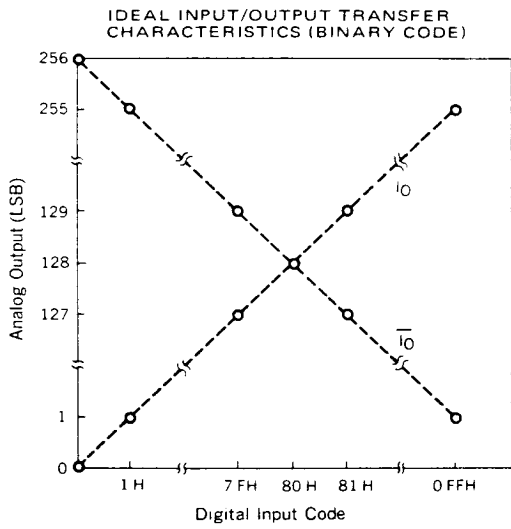

18PIN PLASTIC DIP (300 mil)

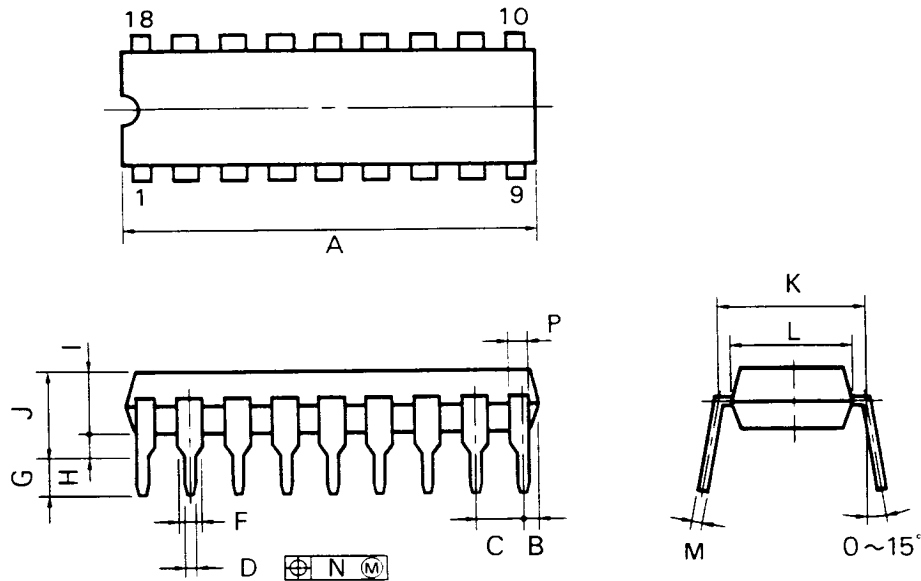

P18C-100-300A.C

NOTES

- 1) Each lead centerline is located within 0.25 mm (0.01 inch) of its true position (T.P.) at maximum material condition.
- 2) Item "K" to center of leads when formed parallel.

ITEM	MILLIMETERS	INCHES
A	22.86 MAX.	0.900 MAX.
B	1.27 MAX.	0.050 MAX.
C	2.54 (T.P.)	0.100 (T.P.)
D	0.50 ^{+0.10}	0.020 ^{+0.004}
F	1.2 MIN.	0.047 MIN.
G	3.5 ^{+0.3}	0.138 ^{+0.012}
H	0.51 MIN.	0.020 MIN.
I	4.31 MAX.	0.170 MAX.
J	5.08 MAX.	0.200 MAX.
K	7.62 (T.P.)	0.300 (T.P.)
L	6.4	0.252
M	0.25 ^{+0.05}	0.010 ^{+0.004}
N	0.25	0.01
P	1.0 MIN.	0.039 MIN.