

TC4019BP/TC4019BF QUAD AND/OR SELECT GATE

TC4019BP/BF is four circuit AND-OR SELECT GATE. The basic circuit consists of two 2 input AND gates and an OR gate receiving two outputs from the AND gates. The input signals applied to An and Bn (n=1~4) are selected by the common selection input to all the four circuits, KA and KB and the outputs are obtained at Dn.

This is suitable for data selectors and multiplexers of 4 bits 2 channels.

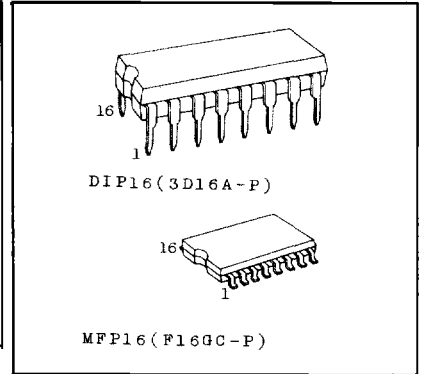

ABSOLUTE MAXIMUM RATINGS

CHARACTERISTIC	SYMBOL	RATING	UNIT
DC Supply Voltage	V _{DD}	V _{SS} - 0.5 ~ V _{SS} + 20	V
Input Voltage	V _{IN}	V _{SS} - 0.5 ~ V _{DD} + 0.5	V
Output Voltage	V _{OUT}	V _{SS} - 0.5 ~ V _{DD} + 0.5	V
DC Input Current	I _{IN}	±10	mA
Power Dissipation	P _D	300(DIP)/180(MFP)	mW
Operating Temperature Range	T _A	-40 ~ 85	°C
Storage Temperature Range	T _{stg}	-65 ~ 150	°C
Lead Temp./Time	T _{sol}	260°C · 10 sec	

PIN ASSIGNMENT

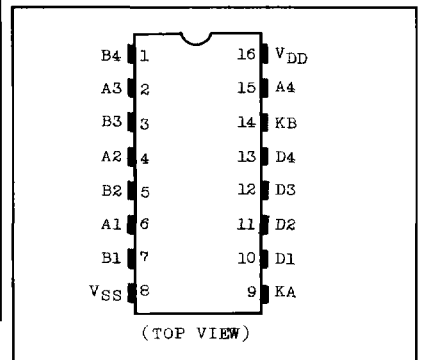

LOGIC DIAGRAM

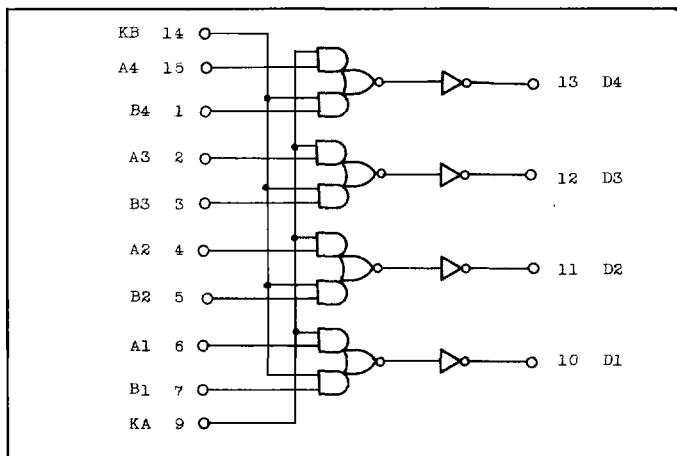

TRUTH TABLE

INPUTS				OUTPUT
KA	KB	A _n	B _n	D _n
H	L	H	*	H
H	L	L	*	L
L	H	*	H	H
L	H	*	L	L
L	L	*	*	L
H	H	L	L	L
H	H	L	H	H
H	H	H	L	H
H	H	H	H	H

L : LOW LEVEL
H : HIGH LEVEL
* : DON'T CARE

TC4019BP/BF

RECOMMENDED OPERATING CONDITIONS (V_{SS}=0V)

CHARACTERISTIC	SYMBOL	MIN.	TYP.	MAX.	UNITS
DC Supply Voltage	V _{DD}	3	-	18	V
Input Voltage	V _{IN}	0	-	V _{DD}	V

STATIC ELECTRICAL CHARACTERISTICS (V_{SS}=0V)

CHARACTERISTIC	SYMBOL	TEST CONDITIONS	V _{DD} (V)	-40°C		25°C			85°C		UNITS
				MIN.	MAX.	MIN.	TYP.	MAX.	MIN.	MAX.	
High-Level Output Voltage	V _{OH}	I _{OUT} < 1μA V _{IN} =V _{SS} , V _{DD}	5	4.95	-	4.95	5.00	-	4.95	-	V
			10	9.95	-	9.95	10.00	-	9.95	-	
			15	14.95	-	14.95	15.00	-	14.95	-	
Low-Level Output Voltage	V _{OL}	I _{OUT} < 1μA V _{IN} =V _{SS} , V _{DD}	5	-	0.05	-	0.00	0.05	-	0.05	V
			10	-	0.05	-	0.00	0.05	-	0.05	
			15	-	0.05	-	0.00	0.05	-	0.05	
Output High Current	I _{OH}	V _{OH} =4.6V V _{OH} =2.5V V _{OH} =9.5V V _{OH} =13.5V V _{IN} =V _{SS} , V _{DD}	5	-0.61	-	-0.51	-1.0	-	-0.42	-	mA
			5	-2.5	-	-2.1	-4.0	-	-1.7	-	
			10	-1.5	-	-1.3	-2.2	-	-1.1	-	
			15	-4.0	-	-3.4	-9.0	-	-2.8	-	
			5	0.61	-	0.51	1.2	-	0.42	-	
Output Low Current	I _{OL}	V _{OL} =0.4V V _{OL} =0.5V V _{OL} =1.5V V _{IN} =V _{SS} , V _{DD}	5	0.61	-	0.51	1.2	-	0.42	-	mA
			10	1.5	-	1.3	3.2	-	1.1	-	
			15	4.0	-	3.4	12.0	-	2.8	-	
			5	3.5	-	3.5	2.75	-	3.5	-	
			10	7.0	-	7.0	5.5	-	7.0	-	
Input High Voltage	V _{IH}	V _{OUT} =0.5V, 4.5V V _{OUT} =1.0V, 9.0V V _{OUT} =1.5V, 13.5V I _{OUT} < 1μA	5	3.5	-	3.5	2.75	-	3.5	-	V
			10	7.0	-	7.0	5.5	-	7.0	-	
			15	11.0	-	11.0	8.25	-	11.0	-	
Input Low Voltage	V _{IL}	V _{OUT} =0.5V, 4.5V V _{OUT} =1.0V, 9.0V V _{OUT} =1.5V, 13.5V I _{OUT} < 1μA	5	-	1.5	-	2.25	1.5	-	1.5	V
			10	-	3.0	-	4.5	3.0	-	3.0	
			15	-	4.0	-	6.75	4.0	-	4.0	
			5	-	0.1	-	10 ⁻⁵	0.1	-	1.0	
			18	-	-0.1	-	10 ⁻⁵	-0.1	-	-1.0	
Quiescent Device Current	I _{DD}	V _{IN} =V _{SS} , V _{DD} *	5	-	0.25	-	0.001	0.25	-	7.5	μA
			10	-	0.5	-	0.001	0.5	-	15	
			15	-	1.0	-	0.002	1.0	-	30	

* All valid input combinations

DYNAMIC ELECTRICAL CHARACTERISTICS (Ta=25°C, V_{SS}=0V, C_L=50pF)

CHARACTERISTIC	SYMBOL	TEST CONDITION	V _{DD} (V)	MIN.	TYP.	MAX.	UNITS
Output Transition Time (Low to High)	t _{TLH}		5	-	70	200	ns
			10	-	35	100	
Output Transition Time (High to Low)	t _{THL}		15	-	30	80	
Propagation Delay Time (A, B - D)	t _{pLH} t _{pHL}		5	-	75	300	
			10	-	40	120	
			15	-	30	100	
Propagation Delay Time (KA, KB - D)	t _{pLH} t _{pHL}		5	-	75	300	
			10	-	40	120	
			15	-	30	100	
Input Capacitance	C _{IN}	An, Bn Input		-	5	7.5	pF
		KA, KB Input		-	12	20	

WAVEFORM FOR MEASUREMENT OF DYNAMIC CHARACTERISTICS

