

# DN74LS38

## Quad 2-input Positive NAND Buffers (with Open Collector Outputs)

### Description

DN74LS38 contains four 2-input positive isolation NAND buffer gate circuits with open collector outputs.

### Features

- “Wired” AND capability
- High fan-out ( $I_{OL} = 24\text{mA}$  maximum)
- Low power consumption ( $P_d = 17.5\text{mW}$  typical)
- High speed ( $t_{pd} = 19\text{ns}$  typical)
- Wide operating temperature range ( $T_a = -20$  to  $+75^\circ\text{C}$ )

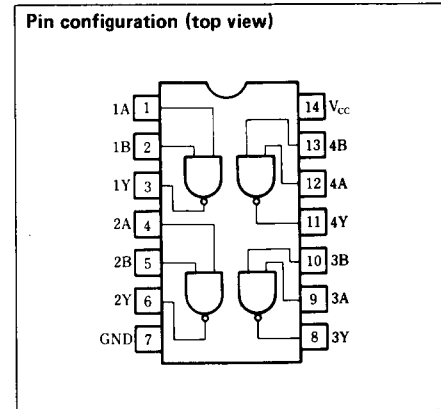
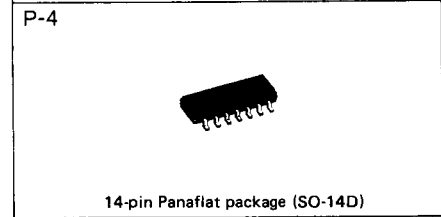
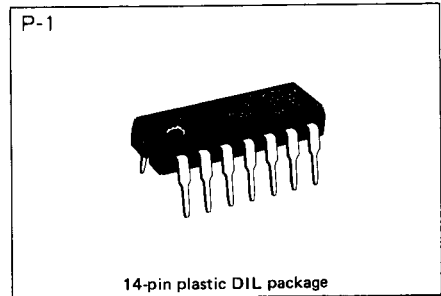

### Recommended operating conditions

Parameter	Sym	Min	Typ	Max	Unit
Supply voltage	$V_{CC}$	4.75	5.00	5.25	V
HIGH level output voltage	$V_{OH}$			5.5	V
LOW level output voltage	$I_{OL}$			24	mA
Operating temperature range	$T_{opr}$	-20	25	75	$^\circ\text{C}$

■ DC characteristics (Ta = -20 ~ +75°C)

Parameter	Sym	Test conditions		Min	Typ*	Max	Unit
Input voltage	V <sub>IH</sub>			2.0			V
	V <sub>IL</sub>					0.8	V
Output voltage	V <sub>OL1</sub>	V <sub>CC</sub> = 4.75 V	I <sub>OL</sub> = 12 mA		0.25	0.4	V
	V <sub>OL2</sub>	V <sub>IH</sub> = 2 V	I <sub>OL</sub> = 24 mA		0.35	0.5	V
Input current	I <sub>IH</sub>	V <sub>CC</sub> = 5.25 V	V <sub>I</sub> = 2.7 V			20	μA
	I <sub>IL</sub>	V <sub>CC</sub> = 5.25 V	V <sub>I</sub> = 0.4 V			-0.4	mA
	I <sub>I</sub>	V <sub>CC</sub> = 5.25 V	V <sub>I</sub> = 7 V			0.1	mA
Output current	I <sub>OH</sub>	V <sub>CC</sub> = 4.75 V, V <sub>I</sub> = 0.8 V	V <sub>OH</sub> = 5.5 V			250	μA
Input clamp voltage	V <sub>IK</sub>	V <sub>CC</sub> = 4.75 V	I <sub>I</sub> = -18 mA			-1.5	V
Supply current	I <sub>CCH</sub>	V <sub>CC</sub> = 5.25 V			0.9	2.0	mA
	I <sub>CCL</sub>	V <sub>CC</sub> = 5.25 V			6	12	mA

\* When constant at V<sub>CC</sub> = 5V, Ta = 25°C.

■ Switching characteristics (V<sub>CC</sub> = 5V, Ta = 25°C)

Parameter	Sym	Test conditions	Min	Typ	Max	Unit
Propagation delay time	t <sub>PLH</sub>	C <sub>L</sub> = 45 pF, R <sub>L</sub> = 667 Ω		20	32	ns
	t <sub>PHL</sub>			18	28	ns

※ Switching parameter measurement information

1. Measurement circuit

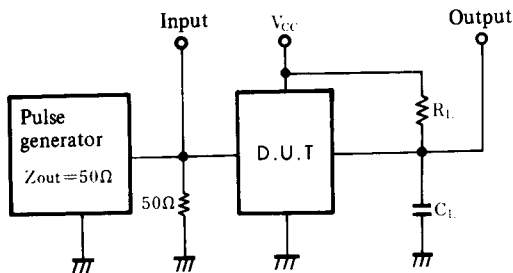

Notes

- C<sub>L</sub> includes probe and tool floating capacitance.
- Diodes are all MA161 or equivalent.

2. Waveforms

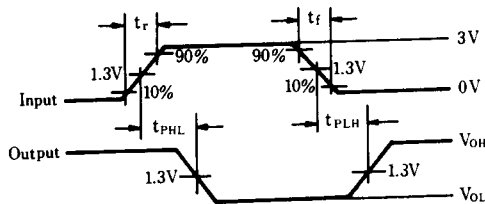

Notes

- Input waveform: t<sub>r</sub> ≤ 15ns, t<sub>f</sub> ≤ 6ns, PRR = 1MHz, duty cycle = 50%.