

NPN SILICON EPITAXIAL TRANSISTOR
FOR UHF-BAND POWER AMPLIFIER
INDUSTRIAL USE

DESCRIPTION

The 2SC2586 is an NPN silicon epitaxial transistor designed for UHF-band medium power amplifiers.

FEATURES

- Medium power output
 $P_{out} = 1.6 \text{ W TYP. @ } f = 500 \text{ MHz, } V_{CC} = 12.6 \text{ V, } P_{in} = 0.2 \text{ W}$

ABSOLUTE MAXIMUM RATINGS ($T_A = 25 \text{ }^\circ\text{C}$)

PARAMETER	SYMBOL	RATINGS	UNIT
Collector to Base Voltage	V_{CBO}	35	V
Collector to Emitter Voltage	V_{CEO}	18	V
Emitter to Base Voltage	V_{EBO}	3.0	V
Collector Current	I_C	0.4	A
Total Power Dissipation	$P_T (T_C = 25 \text{ }^\circ\text{C})$	7	W
Junction Temperature	T_J	200	$^\circ\text{C}$
Storage Temperature	T_{stg}	-65 to +200	$^\circ\text{C}$

PACKAGE DIMENSIONS (in millimeters)

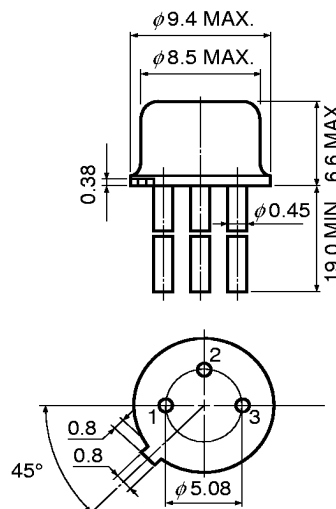

PIN CONNECTIONS

1. Collector
2. Base
3. Emitter

ELECTRICAL CHARACTERISTICS ($T_A = 25 \text{ }^\circ\text{C}$)

PARAMETER	SYMBOL	TEST CONDITIONS	MIN.	TYP.	MAX.	UNIT
Collector Cut-off Current	I_{CBO}	$V_{CB} = 20 \text{ V, } I_C = 0$			0.1	mA
Emitter Cut-off Current	I_{EBO}	$V_{EB} = 2 \text{ V, } I_E = 0$			0.1	mA
DC Current Gain	h_{FE}	$V_{CE} = 10 \text{ V, } I_C = 100 \text{ mA (pulse)}$	20	60	200	-
Output Capacitance	C_{ob}	$V_{CB} = 10 \text{ V, } I_E = 0, f = 1.0 \text{ MHz}$		2.5	4.0	pF
Output Power	P_{out}	$f = 500 \text{ MHz, } V_{CC} = 12.6 \text{ V, } P_{in} = 23 \text{ dBm}$	30.5	32		dBm
Collector Efficiency	η_C		55	65		%

TYPICAL CHARACTERISTICS (T_A = 25 °C)

